

OPERATION MANUAL

DAKOTA ULTRASONICS

MMX-7

Data Logging Thickness Gauge

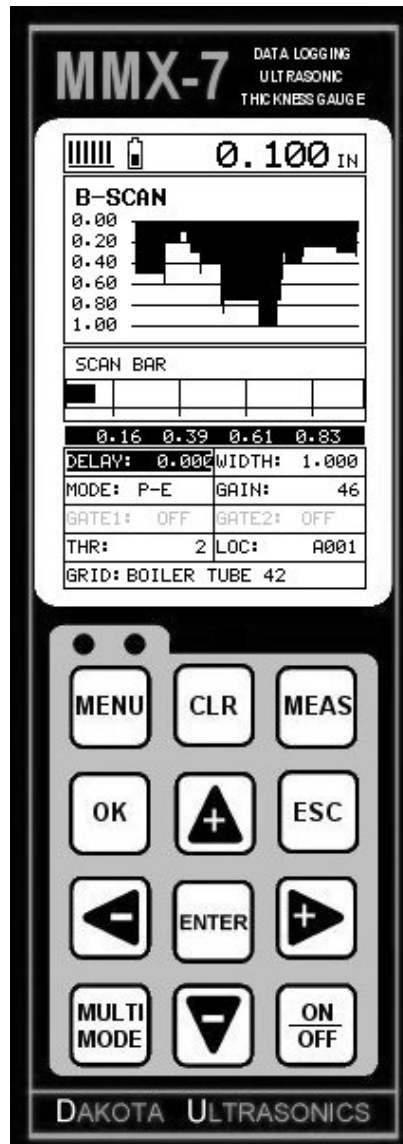

CHAPTER ONE INTRODUCTION	1
CHAPTER TWO QUICK STARTUP GUIDE	2
CHAPTER THREE KEYBOARD, MENU, & CONNECTOR REFERENCE.....	12
CHAPTER FOUR PRINCIPALS OF ULTRASONIC MEASUREMENT	21
CHAPTER FIVE SELECTING THE MEASUREMENT MODE	25
CHAPTER SIX MAKING MEASUREMENTS	28
CHAPTER SEVEN USING THE DIGITS & B-SCAN DISPLAYS	41
CHAPTER EIGHT THRU PAINT MEASUREMENT TECHNIQUE	53
CHAPTER NINE ADDITIONAL FEATURES OF THE MMX-7.....	54
CHAPTER TEN DATA STORAGE – SETUP, EDIT, & VIEW GRIDS	58
CHAPTER ELEVEN SETUPS – CREATE, STORE, EDIT, & RECALL	75
CHAPTER TWELVE USING THE UTILITY SOFTWARE.....	81
APPENDIX A - VELOCITY TABLE.....	82
APPENDIX B - SETUP LIBRARY.....	84

CHAPTER ONE INTRODUCTION

The Dakota Ultrasonics model **MMX-7** is a digital ultrasonic thickness gauge with a time based B-Scan and alpha numeric data logger. Based on the same operating principles as SONAR, the **MMX-7** is capable of measuring the thickness of various materials with accuracy as high as ± 0.001 inches, or ± 0.01 millimeters. The principle advantage of ultrasonic measurement over traditional methods is that ultrasonic measurements can be performed with access to only one side of the material being measured.

Dakota Ultrasonics maintains a customer support resource in order to assist users with questions or difficulties not covered in this manual. Customer support may be reached at any of the following:

- Dakota Ultrasonics Corporation,
1500 Green Hills Road, #107 Scotts Valley, CA
95066 USA
- Telephone: (831) 431-9722
- Facsimile: (831) 431-9723
- www.dakotaultrasonics.com

1.1 Disclaimer

Inherent in ultrasonic thickness measurement is the possibility that the instrument will use the second rather than the first echo from the back surface of the material being measured. This may result in a thickness reading that is TWICE what it should be. Responsibility for proper use of the instrument and recognition of this phenomenon rest solely with the user of the instrument.

CHAPTER TWO QUICK STARTUP GUIDE

Turn the **MMX-7** on and off using the switch located on the bottom right corner of the keypad. When **MMX-7** is initially turned on, a flash logo and blinking lights will be displayed prior to entering into the main measurement screen. Note: This section is primarily written as a basic startup guide only.

2.1 Selecting The Transducer Type

The first step in using the **MMX-7** is to select the transducer type according to frequency and diameter. By selecting the transducer type from a predefined list, the **MMX-7** can recall specific properties about the transducer. **Note:** Once the transducer has been selected, the **MMX-7** will store and recall this transducer type every time the **MMX-7** is powered on/off. The type will only change if the user physically selects another transducer type from the list, or selects a previously saved setup. Therefore, if you have previously gone through this section and selected the transducer you are using, proceed to the next section. Use the following steps to select your transducer type:

Selecting the Transducer Type

1. 3/16IN - 5.0MHZ	
2. 3/16IN - 7.5MHZ	
3. 3/16IN - 10.0MHZ	
4. 1/4IN - 1.0MHZ	
5. 1/4IN - 2.25MHZ	
6. 1/4IN - 5.0MHZ	
7. 1/4IN - 5.0MHZ HD	
8. 1/4IN - 7.5MHZ	
PROBE	CAL DISP SETUP DATA
ZERO	TRANSDUCER
TYPE	1
GAIN	MED
MEASURE MODE	P-E

- 1) Press the **MENU** key once to activate the menu items tab. Press the **MENU** key multiple times to tab right and the **ESC** key multiple times to tab left until the **PROBE** menu is highlighted and displaying the submenu items.
- 2) Use the **UP** and **DOWN** arrow keys to scroll through the sub menu items until **TYPE** is highlighted.

- 3) Press the **ENTER** key to display the list of transducer types.
- 4) Press the **UP** and **DOWN** arrow keys to scroll through the transducer list until the appropriate type is highlighted.
- 5) Press the **ENTER** key to display the confirmation screen.
- 6) Press the **OK** key to select the transducer and return to the menu screen, or **ESC** to cancel the selecting the transducer.

2.2 Probe Zero & Calibration

The next step is to calibrate the **MMX-7** to the material and transducer being used. If the materials sound velocity is unknown, the **MMX-7** can be calibrated to a known thickness sample. This demo will briefly explain both of these techniques.

In either case, the transducer **MUST** be zeroed on the probe zero disk (battery cover) located on the top of the unit as follows:

Performing a Probe Zero

PROBE	CAL	DISP	SETUP	DATA
ZERO TRANSDUCER				
TYPE				1
GAIN				MED
MEASURE	MODE			P-E

- 1) Apply a drop of couplant on the transducer and place the transducer in steady contact with the probe zero disk, and obtain a steady reading.
- 2) Assuming the probe menu is still displayed from the previous type selection, use the **UP** and **DOWN** arrow keys to scroll through the sub menu items until **ZERO TRANSDUCER** is highlighted.
- 3) Press the **ENTER** key to display the confirmation screen.

- 4) Press the **OK** key to complete the probe zero function, or **ESC** key to cancel the probe zero function.
- 5) Remove the transducer from the probe zero disk, and proceed to the calibration section.

Note: The value that is displayed will change depending on the current velocity setting in the **MMX-7**. Disregard the number that is displayed. **It is not important.** What is important is accurately performing the steps outlined above to insure reliability of the probe zero calculation.

Known Velocity

If the material velocity is known, the user may wish to simply enter the velocity number into the **MMX-7**, rather than have the **MMX-7** calculate the velocity value on using a know thickness. The steps for entering the velocity are outlined below:

Using a Known Material Velocity

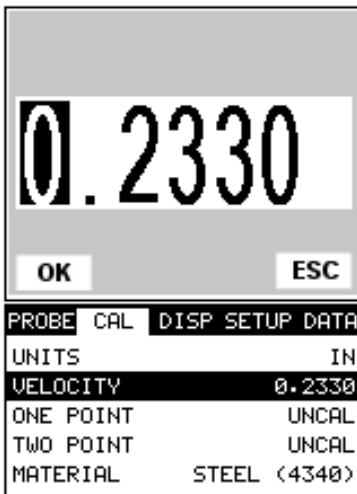

- 1) Press the **MENU** key once to activate the menu items tab. Press the **MENU** key multiple times to tab right and the **ESC** key multiple times to tab left until the **CAL** menu is highlighted and displaying the submenu items.

- 2) Use the **UP** and **DOWN** arrow keys to scroll through the sub menu items until **VELOCITY** is highlighted.
- 3) Press the **ENTER** key to display the **Digits Edit Box**.
- 4) Press the **UP** and **DOWN** arrow keys to scroll the highlighted value.
- 5) Press the **LEFT** and **RIGHT** arrow keys to scroll the digit locations.
- 6) Repeat steps **4 & 5** until the velocity number is correctly displayed.
- 7) Press the **OK** key to set the velocity and return to the menu screen, or **ESC** to cancel entering the velocity.
- 8) Finally, press the **MEAS** key to return to the measurement screen and begin taking readings.

Known Thickness

Sometimes the sound velocity of a material is unknown. In this case a sample with a known thickness can be used to determine the sound velocity. It would be very handy to carry a set of mechanical calipers to use in conjunction with the **MMX-7** for calibration in the field:

Using a Known Thickness

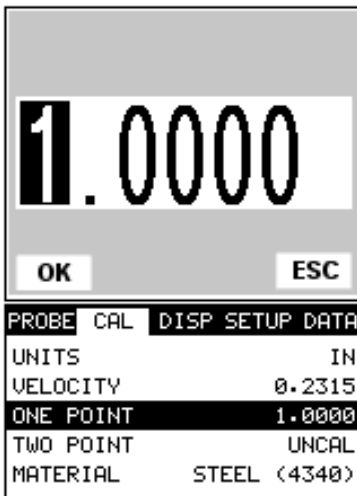

Note: Be sure that the probe zero procedure has been performed prior to performing this calibration procedure.

- 1) Physically measure an exact sample of the material or a location directly on the material to be measured using a set of calipers or a digital micrometer.
- 2) Apply a drop of couplant on the transducer and place the transducer in steady contact with the sample or actual test material. Be sure that the reading is stable and the repeatability indicator, in the top left corner of the display, is fully lit and stable. Press the **MENU** key once to activate the menu items tab. Press the **MENU** key multiple times to tab right and the **ESC** key multiple times to tab left until the **CAL** menu is highlighted and displaying the submenu items.

- 3) Use the **UP** and **DOWN** arrow keys to scroll through the sub menu items until **ONE POINT** is highlighted.
- 4) Press the **ENTER** key to display the **Digits Edit Box**.
- 5) Press the **UP** and **DOWN** arrow keys to scroll the highlighted value.
- 6) Press the **LEFT** and **RIGHT** arrow keys to scroll the digit locations.
- 7) Repeat steps **5 & 6** until the known thickness value is correctly displayed.
- 8) Press the **OK** key to calculate the velocity and return to the menu screen, or **ESC** to cancel entering the velocity.
- 9) Finally, press the **MEAS** key to return to the measurement screen and begin taking readings.

Note: CHECK YOUR CALIBRATION! Place the transducer back on the calibration point. The thickness reading should now match the known thickness. If the thickness is incorrect, repeat the steps above.

Basic Material Type

If the material velocity is unknown, and a sample thickness cannot be taken from the material, the user may opt to choose a basic material type from a list with approximate velocity numbers. It's important to note that these velocities will not always be an exact representation of the material being tested. Use these values only if a close approximation is acceptable. Follow the steps below to select a basic material type:

Selecting a Basic Material Type

PROBE	CAL	DISP	SETUP	DATA
ZERO TRANSDUCER				
TYPE				1
GAIN				MED
MEASURE	MODE			P-E

- 1) Press the **MENU** key once to activate the menu items tab. Press the **MENU** key multiple times to tab right and the **ESC** key multiple times to tab left until the **CAL** menu is highlighted and displaying the submenu items.
- 2) Use the **UP** and **DOWN** arrow keys to scroll through the sub menu items until **MATERIAL** is highlighted.
- 3) Press the **ENTER** key to display the list of material types.
- 4) Press the **UP** and **DOWN** arrow keys to scroll through the material list until the appropriate material is highlighted.
- 5) Press the **ENTER** key to display the confirmation screen.
- 6) Press the **OK** key to select the material and return to the menu screen, or **ESC** to cancel the material selection.
- 7) Finally, press the **MEAS** key to return to the measurement screen and begin taking readings.

2.3 Measure

The **MMX-7** is now ready to measure. There are two different measurement view options, each with a specific purpose – Digits & B-Scan. The steps below outline how to toggle between the different view mode options:

Selecting the Measurement View Option

PROBE CAL	DISP	SETUP	DATA
VIEW		DIGITS	
BACKLIGHT		OFF	
CONTRAST		10	
BSCAN START		0.00	
BSCAN DEPTH		2.00	

- 1) Press the **MENU** key once to activate the menu items tab. Press the **MENU** key multiple times to tab right and the **ESC** key multiple times to tab left until the **DISP** menu is highlighted and displaying the submenu items.
- 2) Use the **UP** and **DOWN** arrow keys to scroll through the sub menu items until **VIEW** is highlighted.
- 3) Use the **LEFT** and **RIGHT** arrow keys to scroll the view options.
- 4) Once the view is displayed, press the **MEAS** key to return to measurement mode.

DIGITS: Displays the digital thickness value using a larger font size. This view is useful when the MMX-7 is being used as a basic thickness gauge.

BSCAN: The Time Based B-Scan provides the user with a cross sectional view of the material being tested. This mode is useful when there is concern regarding the profile of the blind surface. This can also be a useful view when scanning for pits and flaws.

Once the view has been selected according to the application requirements, the **delay** and **width** of the screen will potentially need to be adjusted, if the view has

been set to **BSCAN**. Use the following steps to adjust these settings directly from the measurement screen as follows:

Adjusting the Start (B-ST) & Depth (B-DEP)

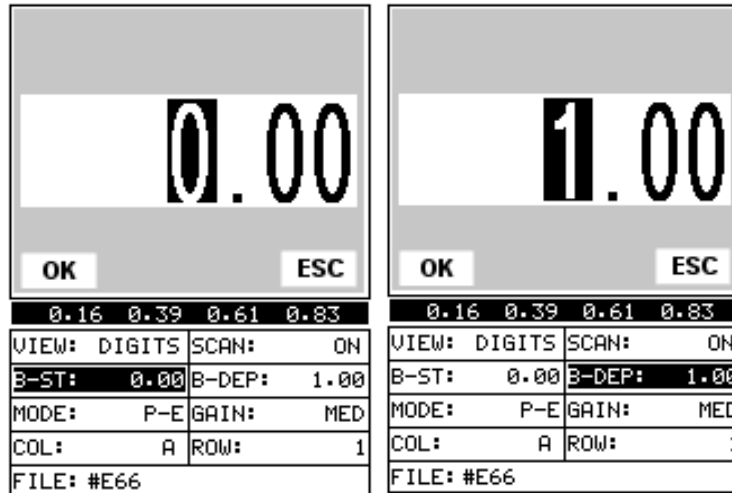

- 1) Press the **MEAS** key once to activate the measure menu items. Press the **MEAS** key multiple times to move right and the **ESC** key multiple times to move left, until the either the **B-ST** or **B-DEP** cell is highlighted.
- 2) Use the **UP**, **DOWN**, **LEFT**, or **RIGHT** arrow keys to scroll the **B-ST** and **B-DEP** values.
- 3) Repeat steps 1 & 2 until the range is correctly being displayed.

Alternatively, the **B-ST** and **B-DEP** values can be changed using the **Digit Edit Box** as follows:

- 1) Press the **MEAS** key once to activate measure menu items. Press the **MEAS** key multiple times to move right and the **ESC** key multiple times to move left, until the either the **B-ST** or **B-DEP** cell is highlighted.
- 2) Press the **ENTER** key to display the digits edit box.
- 3) Press the **UP** and **DOWN** arrow keys to scroll the highlighted value.

- 4) Press the **LEFT** and **RIGHT** arrow keys to scroll the digit locations.
- 5) Repeat steps 3 & 4 until the **B-ST** or **B-DEP** value is correctly displayed.
- 6) Press the **OK** key to set the **B-ST** and **B-DEP** value and return to the measure screen, or **ESC** to cancel entering the **B-ST** or **B-DEP** value.
- 7) Finally, press the **MEAS** key to return to the measurement screen and begin taking readings.

Note: The **B-ST & B-DEP** can also be adjusted from the menu tab items. However, using the hot menu keys is the easiest method.

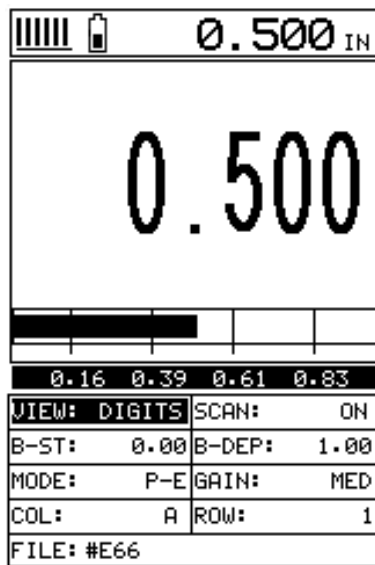

DIGITS

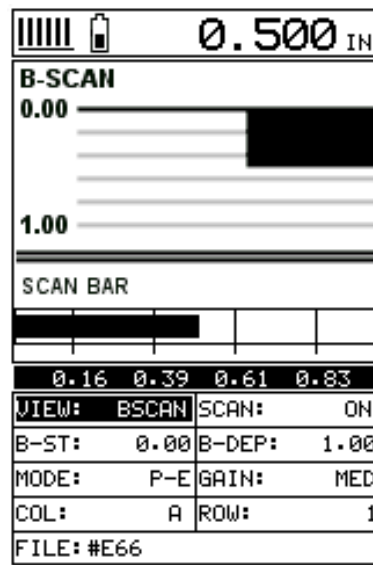

B-SCAN

In the upper left corner of each of the mode photos above, is the repeatability indicator. The repeatability indicator is represented by six vertical bars and represents how repeatable the measurements are. In regular measurement mode, the **MMX-7** makes 4 measurements a second. In scan mode, the **MMX-7** makes 32 measurements a second. When the **MMX-7** is idle, only the left vertical bar and the underline will be displayed. However, when the **MMX-7** is making a measurement, five or six of the bars should be displayed on the repeatability indicator. If fewer than five bars are showing, the **MMX-7** is having difficulty achieving a stable measurement and the thickness value displayed is potentially be unstable.

CHAPTER THREE KEYBOARD, MENU, & CONNECTOR REFERENCE



3.1 Menu Key (Operation & Sub Menus)

The **Menu** key activates the primary menu structure containing 9 menu tab groups. These tab groups then contain sub menu items, or functions. The sub menu items have been organized in tab groups according to how closely they are related to the individual tab group names. Let's first get familiar with how to move around in these tabs before continuing on to the sub menu functions. This procedure is outlined below:

Activating and Getting Around in the Menu Items

PROBE	CAL	DISP	SETUP	DATA
ZERO TRANSDUCER				
TYPE				1
GAIN				MED
MEASURE MODE				P-E

- 1) Press the **MENU** key once to activate the menu items tab. Press the **MENU** key multiple times to tab right, and the **ESC** key multiple times to tab left until the desired tab group is highlighted and displaying the submenu items.

Now that your familiar with activating and moving amongst the tab groups, let's have a look at how to move around in the sub menu items as follows:

Getting Around in the Sub Menu Items

- 1) Use the **UP** and **DOWN** arrow keys to scroll through the sub menu items until the desired function is highlighted.
- 2) Depending on which function is highlighted, use the **LEFT**, **RIGHT**, and **Enter** keys to scroll the options or activate the **Digit Edit** and **List Box** options.

The sections to follow will provide the user with an explanation of the sub menu functions:

PROBE	CAL	DISP	SETUP	DATA
ZERO TRANSDUCER				
TYPE				1
GAIN				MED
MEASURE MODE				P-E

3.2 Probe – Menu

Zero: The **MMX-7** is zeroed in much the same way that a mechanical micrometer is zeroed. If the **MMX-7** is not zeroed correctly, all of the measurements made using the **MMX-7** may be in error by some fixed value. Refer to the section on page 32, for an explanation of this important procedure.

Type: Enables the user to select the type of transducer being used from a chart of transducer types. This provides increased linearity between transducers. Refer to page 28 for a further explanation.

Gain: Increases or decreases the overall amplitude of the signal. Much like turning the volume up or down on a stereo receiver. Refer to page 50 for further info.

AGC: The **MMX-7** is equipped with an automatic gain control when operating in echo-echo mode only. This is much like turning the volume up or down on a stereo receiver. However, the **MMX-7** will automatically control how much the volume is turned up or down. Alternatively, the AGC can be manually controlled using the same procedures as GAIN described above. Refer to page 50 for further info.

Measure Mode: Used to select the measurement mode for different application requirements. The modes are P-E (pulse-echo) and E-E(echo-echo). Refer to page 22 for further info.

PROBE CAL DISP SETUP DATA	
UNITS	IN
VELOCITY	0.2330
ONE POINT	UNCAL
TWO POINT	UNCAL
MATERIAL	STEEL (4340)

3.3 CAL – Menu

Units: Toggle between English or Metric units. The readout will change from inches to millimeters.

Velocity: Function to calibrate the MMX-7 by setting the velocity to a known material velocity. Refer to page 34 for further info.

One Point: Performs a single point calibration. This option allows the user to automatically calculate the velocity by entering a known sample thickness. Refer to page 36 for further info.

Two Point: Performs a two-point calibration. This option allows the user to automatically calculate the velocity by entering a second known sample thickness. Refer to page 37 for further info.

Material: Select the material velocity from a chart of basic material types, when a known sample thickness, or material velocity cannot be obtained. Refer to page 40 for further info.

PROBE CAL DISP SETUP DATA	
VIEW	DIGITS
BACKLIGHT	OFF
CONTRAST	10
BSCAN START	0.00
BSCAN DEPTH	1.00

3.4 DISP (display) – Menu

View: Selectable BSCAN (cross section), and DIGITS (large digits) views. Refer to page 42 for further info.

Backlight: Selectable OFF, ON, AUTO, or INVERT backlight option.

Contrast: Adjustable display contrast for variable light conditions.

B-ST: Provides the user the ability to change the start position of the B-SCAN view. Refer to page 48 for further info.

B-DEP: Provides the user the ability to change the overall depth of the viewable measurement area. It functions a lot like a zoom on a camera. Refer to page 46 for further info.

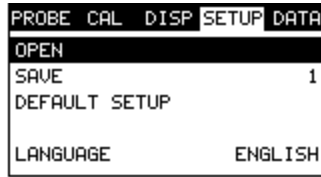

3.5 SETUP – Menu

Open: Displays a list of factory and user defined setups currently stored in memory. These setups can be recalled and used at any time. Refer to page 75 for further info.

Save: Provides the user with the ability to save a custom setup that has been modified or created by the user. Refer to page 77 for further info.

Default Setup: Loads a basic default setup. Use only as a last resort when the setups in the *MMX-7* have been corrupted and a computer is not accessible. Refer to page 79 for further info.

Language: Provides the user the ability to select different languages for the *MMX-7*. Refer to page 79 for further info.

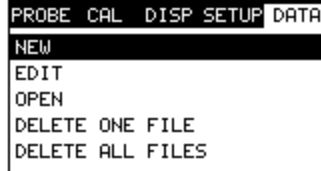

3.6 DATA – Menu

New: Allows the user the ability to create a new alpha numeric grid with custom parameters, rows, and columns depending on their application reporting requirements. Refer to page 58 for further info.

Edit: Gives the user the ability to change parameters of grid that have been previously saved. Note: Pre-defined coordinates cannot be changed once they have been created. Refer to page 70 for further info.

Open: This function provides the user with the ability to recall grids that currently exist in memory from a list of grids. Refer to page 72 for further info.

Delete One Grid: This function provides the user with the ability to delete one individual grid from a list of multiple grids previously saved in memory. Refer to page 68 for further info.

Delete All Grids: This function provides the user with the ability to delete all grids currently stored in memory. Refer to page 68 for further info.

UTIL XFER	
SCAN MODE	OFF
ALARM STATUS	ON
ALARM LO LIMIT	0.000
ALARM HI LIMIT	0.000

3.7 UTIL (utilities) – Menu

Scan Mode: This function enables a hi speed scan mode that increases the overall sample rate from the standard 4 measurements a second to 32 measurements a second. Refer to page 54 for further info.

Alarm Status: Toggles alarm mode on or off. Refer to page 55 for further info.

Alarm LO Limit: Gives the user the ability to set the LO limit parameter. If the measurement falls below this value, a red light will illuminate and sound the internal beeper. Refer to page 56 for further info.

Alarm HI Limit: Gives the user the ability to set the HI limit parameter. If the measurement exceeds this value, a red light will illuminate and sound the internal beeper. Refer to page 57 for further info.

UTIL XFER	
BACKUP SETUP	
RESTORE SETUP	
BACKUP GRID	
RESTORE GRID	
ABOUT	RC 1.4J

3.8 XFER (transfer) – Menu

Backup Setups: Enables the user the ability to backup the setups currently stored in the **MMX-7** to a PC via RS232 port. Refer the help section of the **MMX-7sonicview** software for a complete electronic manual.

Restore Setups: Enables the user the ability to restore the setups currently saved on a PC to an **MMX-7** via RS232 port. Refer the help section of the **MMX-7sonicview** software for a complete electronic manual.

Backup Grid: Enables the user the ability to backup grids currently stored in the **MMX-7** to a PC via RS232 port. Refer the help section of the **MMX-7sonicview** software for a complete electronic manual.

Restore Grid: Enables the user the ability to restore grids currently saved on a PC to an **MMX-7** via RS232 port. Refer the help section of the **MMX-7sonicview** software for a complete electronic manual.

About: Provides the user with Dakota Ultrasonics contact information and the **MMX-7** software version. Refer the help section of the **MMX-7sonicview** software for a complete electronic manual.



3.9 CLR (clear) Key

The primary functions of the **CLR** key, is to clear a measurement from a grid cell location or set obstruct, and backspace in an **Alpha Edit Box**. If a user has already saved a measurement and waveform to a cell location, use this key to clear the measurement at any time.



3.10 MEAS (measurement mode) Key

The **MEAS** key puts the **MMX-7** into it's primary mode of operation. In this mode, the user has a complete view of the LCD, as well as control of the **Hot Menu Functions**. These hot functions provide the user with the ability to make crucial adjustments to the display, feature settings, and grid storage locations without having to search through the menu and sub menu items. It's important to first get familiar with moving around in the hot functions as follows:

Getting Around in the Hot Menus

VIEW:	BSCAN	SCAN:	ON
B-ST:	0.00	B-DEP:	1.00
MODE:	P-E	GAIN:	MED
COL:	A	ROW:	1
FILE:	#E66		

- 1) Press the **MEAS** key at any time to return to the primarily measurement mode.
- 2) Press the **MEAS** key multiple times to tab right through the menu fields, and the **ESC** key multiple times to tab left through the menu fields, until the desired hot function is highlighted.

Now that you're familiar with activating and moving amongst the hot function fields, let's have a look at how to adjust or change the values of these fields:

Adjusting the Values of the Hot Menus

- 1) Use the **UP**, **DOWN**, **LEFT**, and **RIGHT** arrow keys to increase and decrease the values of the hot function fields.
- 2) **Repeat step 1** until the desired value has been achieved.

Alternatively, the B-ST and B-DEP hot function fields can be changed using the **Digit Edit Box** as follows:

- 1) Press the **ENTER** key to display the **Digits Edit Box**.
- 2) Press the **UP** and **DOWN** arrow keys to scroll the highlighted value.
- 3) Press the **LEFT** and **RIGHT** arrow keys to scroll the digit locations.
- 4) Repeat steps **2 & 3** until the delay, width, gain, or threshold number is correctly displayed.
- 5) Press the **OK** key to set and return to the measure screen, or **ESC** to cancel entering the B-ST or B-DEP values.

3.11 OK Key

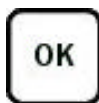

The primary function of the **OK** key is confirmation of a change or selection. It also toggles the view from B-SCAN to DIGITS in previously saved grid location.

3.12 ESC Key



The **ESC** key is used in the **MENU**, **MEAS**, and **EDIT** functions as a back or escape function. It also toggles the view from B-SCAN to DIGITS in previously saved grid location.

3.13 Arrow Keys



The **Arrow Keys** are used to navigate through the menus, increase/decrease values, and toggle specific function keys.

3.14 ENTER key



The **ENTER** key is used in the overall menu selection process, to activate list and edit boxes, and save measurements to grid locations.

3.15 MULTI MODE Key



The **MULTI MODE** key toggles the measurement mode of the **MMX-7**, from pulse-echo (flaw mode), to echo-echo (thru paint) mode. This is a quick automatic preset mode that enables the user to change modes without having to manually adjust the mode between pulse-echo and echo-echo. Both modes have been configured for use with any transducer type selected.

3.16 ON/OFF Key



The **ON/OFF** key simply powers the unit either **ON** or **OFF**. Note: Unit will automatically power off when idle for 5 minutes. All current settings are saved prior to powering off.

3.17 Top & Bottom End Caps

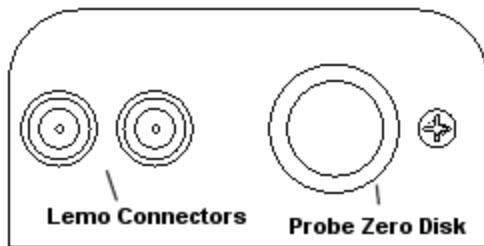

Top End Cap

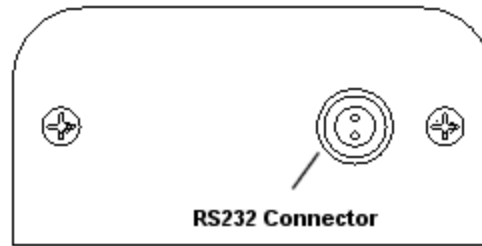

Bottom End Cap

The top & bottom end panels are where all connections are made to the **MMX-7**. The diagram above shows the layout and description of the connectors:

Transducer Connectors

Refer to Diagram: The transducer connectors, and battery cover/probe zero disk are located on the **MMX-7's** top end cap. The transducer connectors are of type Lemo "00". Note: There is no polarity associated with connecting the transducer to the **MMX-7**.

Probe Zero Disk & Battery Cover

Refer to Diagram: The Battery cover is the large round disk shown in the diagram. **Note:** This same disk is also used as a probe zero disk. Simply remove the cover when replacing the batteries (3 AA cells). When performing a probe zero function, simply place the transducer on disk making firm contact. **Important:** Be sure to follow the polarity labels located on the back label of the **MMX-7**. **Note:** Rechargeable batteries can be used, however they must be recharged outside of the unit in a stand alone battery charger.

RS-232 Connector

Refer to Diagram: The **RS-232** connector, located on the bottom end cap, is a 2 pin female Lemo connector. It is designed to connect directly from the **MMX-7** to a standard AT serial port on a PC. The cable supplied with the **MMX-7** is a Lemo to 9 pin serial cable. **Note:** This connector is also used to upgrade the **MMX-7** with the latest version of firmware.

CHAPTER FOUR PRINCIPALS OF ULTRASONIC MEASUREMENT

4.1 Time versus thickness relationship

Ultrasonic thickness measurements depend on measuring the length of time it takes for sound to travel through the material being tested. The ratio of the thickness versus the time is known as the sound velocity. In order to make accurate measurements, a sound velocity must be determined and entered into the instrument.

The accuracy of a thickness measurement therefore depends on having a consistent sound velocity. Some materials are not as consistent as others and accuracy will be marginal. For example, some cast materials are very granular and porous and as a result have inconsistent sound velocities.

While there are many different ultrasonic techniques to measure thickness, which will be discussed below, all of them rely on using the sound velocity to convert from time to thickness.

4.2 Suitability of materials

Ultrasonic thickness measurements rely on passing a sound wave through the material being measured. Not all materials are good at transmitting sound.

Ultrasonic thickness measurement is practical in a wide variety of materials including metals, plastics, and glass. Materials that are difficult include some cast materials, concrete, wood, fiberglass, and some rubber.

4.3 Range of measurement and accuracy

The overall measurement capabilities, based on the wide variety of materials, is determined by the consistency of the material being measured

The range of thickness that can be measured ultrasonically depends on the material as well as the technique being used and the type of transducer. Thickness measurements can be made from a minimum of 0.010 inch to 9.999" in steel.

However, the maximum attainable thickness is much less for more attenuative materials (materials that absorb sound).

Accuracy, is determined by how consistent the sound velocity is through the sound path being measured, and is a function of the overall thickness of the material. For example, the velocity in steel is typically within 0.5% while the velocity in cast iron can vary by 4%.

4.4 Couplant

All ultrasonic applications require some medium to couple the sound from the transducer to the test piece. Typically a high viscosity liquid is used as the medium. The sound frequencies used in ultrasonic thickness measurement do not travel

through air efficiently. By using a liquid couplant between the transducer and test piece the amount of ultrasound entering the test piece is much greater.

4.5 Temperature

Temperature has an effect on sound velocity. The higher the temperature, the slower sound travels in a material. High temperatures can also damage transducers and present a problem for various liquid couplants.

Since the sound velocity varies with temperature it is important to calibrate at the same temperature as the material being measured.

Normal temperature range

Most standard transducers will operate from 0°F to 180°F.

High temperature measurements

Special transducers and couplants are available for temperatures above 180°F up to 650°F with intermittent contact. It is necessary to cool the transducer, by submerging the transducer in water between readings, when measuring high temperatures.

Modes and temperature errors

In addition to errors caused by velocity changing with temperature, some modes (measurement techniques) are affected more than others. For example, dual element mode has larger errors due to changes in temperature of the delay line. However, multi-echo techniques help to minimize these errors.

4.6 Measurement Modes

In this section we will discuss the different measurement modes the **MMX-7** is capable of operating in, the transducers required, and the reasons for using specific modes:

Pulse-Echo Mode (Flaw & Pit detection)

Pulse-echo mode measures from the initial pulse (sometimes referred to as an artificial zero) to the first echo (reflection). In this mode, the transducer is placed on a reference disk, located on top of the **MMX-7**, and a key is pressed to establish a zero point for the particular transducer.

In this mode errors result from surface coatings and temperature variations.

Since pulse-echo only requires one reflection, it is the most sensitive mode for measuring weak reflections (flaws) typically found when measuring heavily corroded metals.

V-Path Correction

Dual element delay line transducers have two piezoelectric elements mounted at an angle on one end of the delay line. One element is used for transmitting sound, while the other element only receives sound. The two elements and their delay lines are

packaged in a single housing but acoustically isolated from each other with a sound barrier. This allows the transducer the ability to achieve very high sensitivity for detecting small defects. Also, the surface of the test material does not have to be as flat in order to obtain good measurements.

Dual element transducers are normally used in pulse-echo mode for finding defects, and in echo-echo mode for through coating measurements.

Dual element delay line transducers are usable over a range of 0.025 inches to 20 inches depending on the material, frequency, and diameter.

A limitation of dual element delay-line transducers is the V shaped sound path. Because the sound travels from one element to another, the time versus thickness relationship is non-linear. Therefore, a correction table in the instruments software is used to compensate for this error.

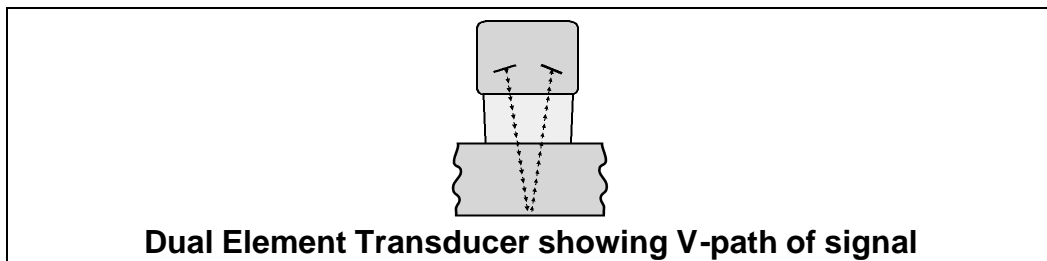

Echo-Echo Mode

The echo-echo mode measures between two reflections. This technique is commonly used to eliminate errors from surface coatings and also to make measurements in multiple layered materials. The disadvantage is that two echoes are needed which requires a much stronger echo (reflection).

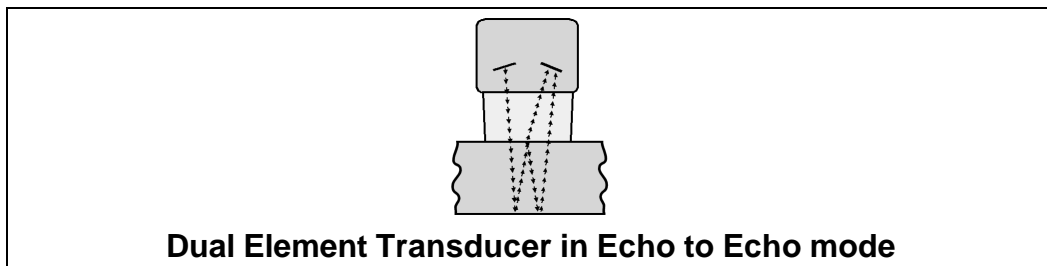

Searching for small defects

Dual element delay line transducers are especially useful in searching for small defects. In the pulse-echo mode with high amplifier gain, very small defects can be measured. This is very useful during corrosion inspections overall. The dual element style transducer will find wall deterioration, pits, and any porosity pockets during tank and pipeline inspections.

4.7 Glossary of terms

Repetition Rate & Display Update

The repetition rate is how often the **MMX-7** generates a burst of ultrasound.

The **MMX-7** has a fixed repetition rate of 1 kHz, or 1000 times per second. The **MMX-7** updates the display 4 times per second in regular measurement mode and 32 times a second in hi speed scan mode. Therefore, the scan mode is most suitable for fast scans of a test piece at a lower resolution.

CHAPTER FIVE SELECTING THE MEASUREMENT MODE

5.1 The setup library

The *MMX-7* contains 64 user configurable preset locations to store custom setups for easy recall. These setups can be optimized for the user's specific application needs and can also be stored on a PC and transferred bi-directionally using Dakota's PC interface software included with the instrument.

The setups supplied with the instrument cover some of the more typical applications commonly used with this type of instrument. These setups can be recalled, modified, and overwritten to one of 64 setup locations. Therefore, these factory setups can also be considered a good starting point to be modified for custom applications. The PC software includes a default setup file that can be uploaded to the gauge at any time to restore factory settings. However, it is recommended that the user consider saving modified setups to an empty location rather than overwriting the factory setups in the *MMX-7*. Once again, these factory settings are excellent starting points for custom setups.

5.2 Which mode & transducer do I use for my application?

High penetration plastics and castings

The most common mode for these types of applications is pulse-echo. The *MMX-7* has been optimized for cast materials. Cast iron applications require 1 - 5MHz frequencies, and cast aluminum requires a 10MHz frequency. Plastics typically require lower frequencies depending on the thickness and make-up of the material. Larger diameters offer greater penetration power because of the crystal size, for difficult to measure materials.

Corrosion & Pit Detection in steel and cast materials

Use pulse-echo mode whenever attempting to locate pits and flaws. Typically a 5MHz transducer, or higher, will be used for these types of applications. Use low frequencies for greater penetration and use higher frequencies for better resolution.

Thru Paint & Coatings

Often times users will be faced with applications where the material will be coated with paint or some other type of epoxy material. Since the velocity of the coating is approximately 2.5 times slower than that of steel, pulse-echo mode will induce error if the coating or paint is not completely removed. By using echo-echo mode, the user is able to successfully measure through both, the coating and steel, and completely eliminate the thickness of the paint or coating. Therefore, the steel can be measured without having to remove the coating prior to measuring. Users will often use pulse-echo mode and echo-echo mode in conjunction when performing inspections on coated materials.

Thru coating measurements require special high damped transducers. The most common transducers are the 3.5, 5, and 7.5MHz hi damped transducers. These transducers are suitable for use in both pulse-echo and echo-echo modes. This conveniently enables the user to accurately measure overall material thickness using the thru Coating mode, and then conveniently switch to pit detection mode without changing transducers. The ¼" 5MHz Hi damped transducer is the most commonly used transducer for standard thru coating applications.

Thin materials

Use pulse echo mode and a high frequency transducer for these types of applications. The most common transducers are the 7.5MHz and 10MHz models with extra resolution. The higher frequencies provide greater resolution and a lower minimum thickness rating overall.

High temperature

Use and select a special 2.25MHz and 5 MHz High temperature transducer for these types of applications. Both pulse-echo and echo-echo modes will also work for these applications. However, echo-echo mode will eliminate error caused by temperature variations in the delay line of the transducer.

Noisy Material

Materials such as titanium, stainless steel, and aluminum may have inherent surface noise issues. This is a signal that appears at the surface of the material when using a dual element delay line probe. Select a higher frequency transducer to reduce this noise – 7.5MHz and higher for better resolution.

Restricted access

In order to measure materials with lots of curvature or restricted access, use and select higher frequencies with smaller diameters. The smallest diameter uses 3/16" crystals with a contact area of .250".

CHAPTER SIX MAKING MEASUREMENTS

The steps involved in making measurements are detailed in this section. The following sections outline how to setup and prepare your **MMX-7** for field use.

In pulse-echo modes, the probe zero must be measured on the reference disk (battery disk) attached to the top of the instrument. This compensates for variations in the transducer. In all modes the sound velocity must be determined. The sound velocity is used to convert the transit time to a physical length. The sound velocity can be selected from a material chart in the manual, selected from a material list in the **MMX-7**, or for greater precision, determined from a sample of the test material that has been mechanically measured. To enter the velocity from a table, look up the material on the chart in the appendix of this manual and refer to the section below on Calibration to a Known Velocity. To determine the velocity of a single sample, refer to the Material Calibration section on page 36.

When measuring curved materials, it is more accurate to calibrate from two test points, one at the minimum limit of the target thickness and one at the maximum limit. In this case the reference disk mounted to the **MMX-7** is not used. This is called two-point calibration and is described on page 37.

6.1 Selecting The Transducer Type

The first step in using the **MMX-7** is to select the transducer type from the transducer list located in the tabbed menu items by frequency and diameter. By selecting the transducer type from a predefined list, the **MMX-7** can recall specific properties about the transducer. **Note:** Once the transducer has been selected, the **MMX-7** will store and recall this transducer type every time the **MMX-7** is powered on/off. The type will only change if the user physically selects another type from the list, or selects a previously saved setup. Therefore, if you have previously gone through this section and selected the transducer you are using, proceed to the next section. Use the following steps to select your transducer type. **Note:** Be sure the transducer type selected is the same as the transducer plugged into the **MMX-7**. **Failure to do this will result in erroneous measurements:**

Selecting the Transducer Type

1.	3/16IN - 5.0MHZ
2.	3/16IN - 7.5MHZ
3.	3/16IN - 10.0MHZ
4.	1/4IN - 1.0MHZ
5.	1/4IN - 2.25MHZ
6.	1/4IN - 5.0MHZ
7.	1/4IN - 5.0MHZ HD
8.	1/4IN - 7.5MHZ
PROBE CAL DISP SETUP DATA	
ZERO TRANSDUCER	
TYPE	1
GAIN	MED
MEASURE MODE	P-E

- 1) Press the **MENU** key once to activate the menu items tab. Press the **MENU** key multiple times to tab right and the **ESC** key multiple times to tab left until the **PROBE** menu is highlighted and displaying the submenu items.
- 2) Use the **UP** and **DOWN** arrow keys to scroll through the sub menu items until **TYPE** is highlighted.
- 3) Press the **ENTER** key to display the list of transducer types.
- 4) Press the **UP** and **DOWN** arrow keys to scroll through the transducer list until the appropriate type is highlighted.
- 5) Press the **ENTER** key to display the confirmation screen.
- 6) Press the **OK** key to select the transducer and return to the menu screen, or **ESC** to cancel the material selection.

Now that the proper transducer has been selected and connected to the **MMX-7**, the measurement mode must be chosen according to the type of application. Following the recommendations in the prior chapter, there are three different ways to select the measurement mode as follows:

Selected from a Setup

LOAD SETUP	
1. ALCAN 332	
2. PRESVES12	
3. REFINE452	
4. LTWING43	
5. LOC54	
6. TANK 99	
7. TANK 11	
PROBE CAL DISP SETUP DATA	
OPEN	
SAVE	1
DEFAULT SETUP	
LANGUAGE	ENGLISH

Important Note: Stored setups will save all the parameters of the **MMX-7**. Therefore, if a transducer was selected in the previous section and a setup is now being recalled, the transducer saved in the setup will overwrite the transducer previously selected. Be sure the transducer saved with the setup is the same as the transducer currently being used. Alternatively, you can select a transducer again after recalling a setup. This will override the transducer saved with the setup.

- 1) Press the **MENU** key once to activate the menu items tab. Press the **MENU** key multiple times to tab right and the **ESC** key multiple times to tab left until the **SETUP** menu is highlighted and displaying the submenu items.
- 2) Use the **UP** and **DOWN** arrow keys to scroll through the sub menu items until **OPEN** is highlighted.
- 3) Press the **ENTER** key to display the list of stored setups.
- 4) Press the **UP** and **DOWN** arrow keys to scroll through the list of setups until the appropriate setup is highlighted.
- 5) Press the **ENTER** key to display the confirmation screen.

- 6) Press the **OK** key to select the setup and return to the menu screen, or **ESC** to cancel the selection process.
- 7) Press the **MEAS** key to return to the measurement screen.

Alternatively, the measurement mode can be simply selected from **the Hot Menu Items** or selected from a sub menu feature as follows:

Hot Menu Selection

VIEW: BSCAN	SCAN: ON
B-ST: 0.00	B-DEP: 1.00
MODE: P-E	GAIN: MED
COL: A	ROW: 1
FILE: #E66	

- 1) Press the **MEAS** key once to activate measure menu items. Press the **MEAS** key multiple times to move right and the **ESC** key multiple times to move left, until the **MODE** cell is highlighted.
- 2) Use the **UP**, **DOWN**, **LEFT**, or **RIGHT** arrow keys to scroll the modes **P-E** (pulse-echo flaws and pits) and **E-E** (echo-echo thru paint) until the target mode is selected.

Finally, the measurement mode can be selected from the menu items as follows:

Selected Using The Tabbed Submenu Items

PROBE	CAL	DISP	SETUP	DATA
ZERO	TRANSDUCER			
TYPE				1
GAIN				MED
MEASURE	MODE			F-E

- 1) Press the **MENU** key once to activate the menu items tab. Press the **MENU** key multiple times to tab right and the **ESC** key multiple times to tab left until the **PROBE** menu is highlighted and displaying the submenu items.
- 2) Use the **UP** and **DOWN** arrow keys to scroll through the sub menu items until **MEASURE MODE** is highlighted.
- 3) Use the **LEFT** and **RIGHT** arrow keys to scroll the mode options. Once the mode is displayed, press the **MEAS** key to return to the measurement mode screen.

6.2 Probe zero

As noted in chapter 3, the probe zero function is a very important and necessary function that must be done prior to calibration. It should also be done on a regular basis. If the **MMX-7** is not zeroed correctly, all of the measurements taken, may be in error by some fixed value. In order to perform a probe zero, the **MMX-7** must be in pulse-echo mode. If echo-echo mode was previously selected in the last section, skip this section and continue on to the next. **Note:** If you intend to switch between measurement modes simultaneously, temporarily select the pulse-echo mode using the hot menu option, perform the probe zero function, and switch back to echo-echo measurement mode after zeroing. The following steps outline the procedure for performing a probe zero:

Performing a Probe Zero

PROBE	CAL	DISP	SETUP	DATA
ZERO TRANSDUCER				
TYPE				1
GAIN				MED
MEASURE MODE				P-E

- 1) Clean the surface of the **Probe Zero Disk**, located on top of the **MMX-7** (battery cover).
- 2) Apply a drop of couplant to the end of the transducer, or probe disk, and hold the transducer in steady contact with the reference disk.
- 3) Press the **MENU** key once to activate the menu items tab. Press the **MENU** key multiple times to tab right and the **ESC** key multiple times to tab left until the **PROBE** menu is highlighted and displaying the submenu items.
- 4) Use the **UP** and **DOWN** arrow keys to scroll through the sub menu items until **ZERO TRANSDUCER** is highlighted.
- 5) Press the **ENTER** key to display the confirmation screen.
- 6) Press the **OK** key to zero the transducer and return to the menu screen, or **ESC** to cancel the zeroing process.
- 7) Remove the transducer from the probe zero disk.
- 8) Press the **MEAS** key to return to the measurement screen.

6.3 Material Calibration

In order for the **MMX-7** to make accurate measurements, it must be set to the correct sound velocity of the material being measured. Different types of materials have different inherent sound velocities. For example, the velocity of sound through steel is about 0.233 inches per microsecond, versus that of aluminum, which is about 0.248 inches per microsecond. If the gauge is not set to the correct sound velocity,

all of the measurements the gauge makes will be erroneous by some fixed percentage.

The **One Point** calibration is the simplest and most commonly used calibration method - optimizing linearity over large ranges. The **Two Point** calibration allows for greater accuracy over small ranges by calculating the probe zero and velocity. The **MMX-7** provides four simple methods for setting the sound-velocity outlined below:

Calibration to a known velocity

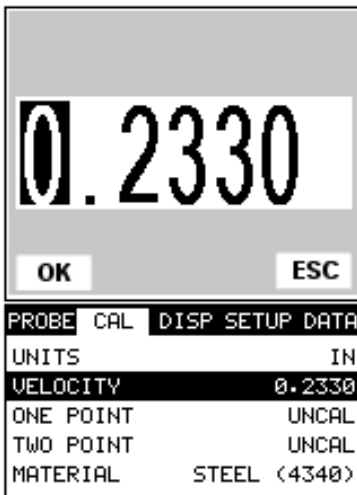

- 1) Press the **MENU** key once to activate the menu items tab. Press the **MENU** key multiple times to tab right, and the **ESC** key multiple times to tab left, until the **CAL** menu is highlighted and displaying the submenu items.
- 2) Use the **UP** and **DOWN** arrow keys to scroll through the sub menu items until **VELOCITY** is highlighted.
- 3) Press the **ENTER** key to display the **Digits Edit Box**.
- 4) Press the **UP** and **DOWN** arrow keys to scroll the highlighted value.
- 5) Press the **LEFT** and **RIGHT** arrow keys to scroll the digit locations.
- 6) Repeat steps **4 & 5** until the velocity number is correctly displayed.
- 7) Press the **OK** key to set the velocity and return to the menu screen, or **ESC** to cancel entering the velocity.

8) Finally, press the **MEAS** key to return to the measurement screen and begin taking readings.

One Point Calibration

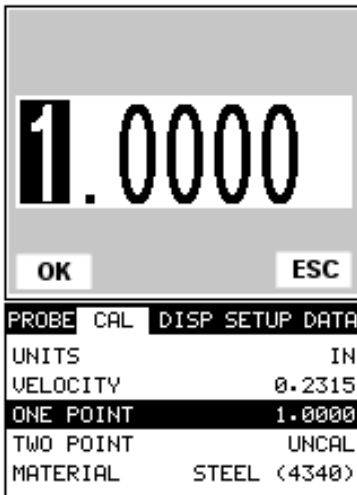

Note: Be sure that a probe zero has been done prior to performing this calibration procedure.

- 1) **Physically measure** a location on the sample to be measured using a set of calipers or a digital micrometer. Note: It's always best to calibrate on the thickest location on the sample, rather than on the thinnest location, as the percentage error is much less with respect to the **MMX-7's** resolution of +/- .001" (0.01mm).
- 2) Apply a drop of couplant on the transducer. Place the transducer in steady contact on the known thickness location. Be sure that the reading is stable and the repeatability indicator, located in the top left corner of the display, is fully lit and stable. Press the **MENU** key once to activate the menu items tab. Press the **MENU** key multiple times to tab right and the **ESC** key multiple times to tab left until the **CAL** menu is highlighted and displaying the submenu items.
- 3) Use the **UP** and **DOWN** arrow keys to scroll through the sub menu items until **ONE POINT** is highlighted.

- 4) Press the **ENTER** key to display the **Digits Edit Box**.
- 5) Press the **UP** and **DOWN** arrow keys to scroll the highlighted value.
- 6) Press the **LEFT** and **RIGHT** arrow keys to scroll the digit locations.
- 7) Repeat steps **5 & 6** until the known thickness value is correctly displayed.
- 8) Press the **OK** key to calculate the velocity and return to the menu screen, or **ESC** to cancel entering the velocity.
- 9) Finally, press the **MEAS** key to return to the measurement screen and begin taking readings.

Note: CHECK YOUR CALIBRATION! Place the transducer back on the calibration point. The thickness reading should now match the known thickness. If the thickness is not correct, repeat the steps above.

Two Point Calibration

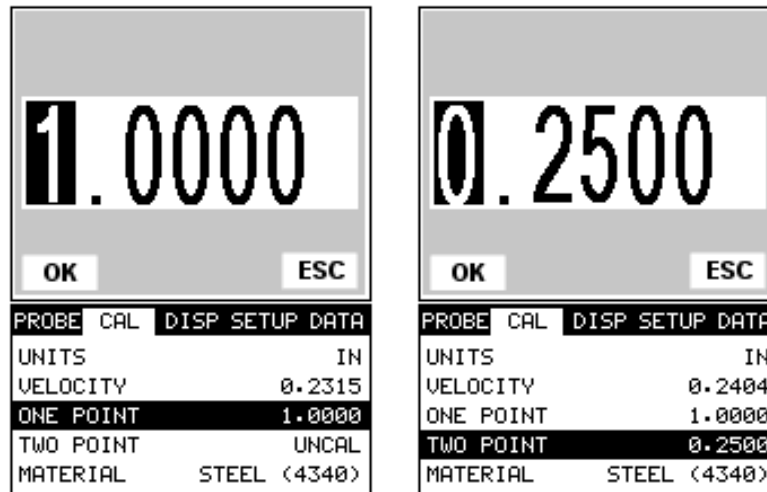

Note: Be sure that a probe zero has been done prior to performing this calibration procedure.

- 1) Using a set of calipers, physically measure two known thickness locations on the sample of material. **Note:** The two locations should represent the desired thickness range being measured. If the range is from .250" - 1.000", then the two known locations should represent this range, or be slightly outside or inside of this range. A typical example would be to find two locations at .236" and the other at 1.047". These thickness points will satisfy the required thickness range noted above.
- 2) Apply a drop of couplant on the transducer. Place the transducer in steady contact on thickest known location first. Be sure that the reading is stable and the repeatability indicator, located in the top left corner of the display, is fully lit and stable. Press the **MENU** key once to activate the menu items tab. Press the **MENU** key multiple times to tab right, and the **ESC** key multiple times to tab left, until the **CAL** menu is highlighted and displaying the submenu items.
- 3) Use the **UP** and **DOWN** arrow keys to scroll through the sub menu items until **ONE POINT** is highlighted.
- 4) Press the **ENTER** key to display the **Digits Edit Box**.
- 5) Press the **UP** and **DOWN** arrow keys to scroll the highlighted value.
- 6) Press the **LEFT** and **RIGHT** arrow keys to scroll the digit locations.
- 7) Repeat steps **5 & 6** until the known thickness value is correctly displayed.
- 8) Press the **OK** key to calculate the velocity for the **ONE POINT** calibration and return to the **CAL** menu screen, or press **ESC** to cancel entering the velocity.
- 9) Apply a drop of couplant on the transducer and place the transducer in steady contact with the sample or actual test material on the thinnest, or

second known thickness location. Be sure that the reading is stable and the repeatability indicator, located in the top left corner of the display, is fully lit and stable.

- 10) Use the **UP** and **DOWN** arrow keys to highlight the **TWO POINT** calibration submenu item.
- 11) Press the **ENTER** key to display the **Digits Edit Box**.
- 12) Press the **UP** and **DOWN** arrow keys to scroll the highlighted value.
- 13) Press the **LEFT** and **RIGHT** arrow keys to scroll the digit locations.
- 14) Repeat steps **12 & 13** until the known thickness value is correctly displayed.
- 15) Press the **OK** key to calculate the velocity for the **TWO POINT** calibration and return to the **CAL** menu screen, or press **ESC** to cancel entering the velocity.
- 16) Finally, press the **MEAS** key to return to the measurement screen and begin taking readings.

Note: CHECK YOUR CALIBRATION! Place the transducer back on both calibration points. The thickness readings should now match the known thickness locations. If they are not correct, repeat the steps above.

Built in Material Selection

SELECT MATERIAL	
1. ALUMINUM	0.2510
2. BERYLLIUM	0.5080
3. BRASS	0.1730
4. BRONZE	0.1390
5. CADMIUM	0.1090
6. COLUMBIUM	0.1940
7. COPPER	0.1830
8. GLASS (PLATE)	0.2270
PROBE	CAL DISP SETUP DATA
UNITS	IN
VELOCITY	0.2404
ONE POINT	1.0000
TWO POINT	UNCAL
MATERIAL	STEEL (4340)

- 1) Press the **MENU** key once to activate the menu items tab. Press the **MENU** key multiple times to tab right, and the **ESC** key multiple times to tab left, until the **CAL** menu is highlighted and displaying the submenu items.
- 2) Use the **UP** and **DOWN** arrow keys to scroll through the sub menu items until **MATERIAL** is highlighted.
- 3) Press the **ENTER** key to display the list of **Material Types**.
- 4) Press the **UP** and **DOWN** arrow keys to scroll through the material list until the appropriate material is highlighted.
- 5) Press the **ENTER** key to display the confirmation screen.
- 6) Press the **OK** key to select the material and return to the menu screen, or press **ESC** to cancel the material selection.
- 7) Finally, press the **MEAS** key to return to the measurement screen and begin taking readings.

CHAPTER SEVEN USING THE DIGITS & B-SCAN DISPLAYS

A key feature of the **MMX-7** is the ability to toggle between two different display options, Digits and B-Scan. The Digits view provides the user with a large digital readout of the thickness. The Digits view also includes a scan bar features that uses a bar graph to indicate thickness. The Scan bar can be very handy while scanning a tank or pipe wall by graphically displaying deflections from pits or internal flaws, rather than having to constantly watch for changes in the digital readout. Just another visual tool to alarm the user when something out of the ordinary is detected.

The B-Scan display is also very useful when scanning surfaces and viewing the cross section of the test material. It provides a convenient way of profiling the blind surfaces during a scan. The B-Scan display is also equipped with a scan bar representing the overall thickness. Once again, the scan bar gives the user a visual indication when a flaw or defect passed over during the scan process. The scan bar will deflect off of the defect and return back to the overall thickness. Visually, this is much easier to notice than watching for changes in the digital value displayed.

Note: The following chapter outlines some of the fine adjustment features of the **MMX-7**. The **MMX-7** has two different display options (**Large Digits and B-Scan**). We'll take a better look at these options in this chapter. **Note:** In order to recall and use the new adjustments made to the **MMX-7** at a later time, the user must save the modified settings in one of the setup locations prior to powering off the unit. Refer page 75 for more information on setups.

7.1 Selecting a Display Option

The following procedure outlines how to select or toggle display options:

Changing Display Options

PROBE CAL	DISP	SETUP	DATA
VIEW			DIGITS
BACKLIGHT			OFF
CONTRAST			10
BSCAN START			0.00
BSCAN DEPTH			1.00

- 1) Press the **MENU** key once to activate the menu items tab. Press the **MENU** key multiple times to tab right, and the **ESC** key multiple times to tab left, until the **DISP** menu is highlighted and displaying the submenu items.

- 2) Use the **UP** and **DOWN** arrow keys to scroll through the sub menu items until **VIEW** is highlighted.
- 3) Use the **LEFT** and **RIGHT** arrow keys to scroll the view options. Once the appropriate view is displayed, press the **MEAS** key to return to the measurement screen.

7.2 Display Views

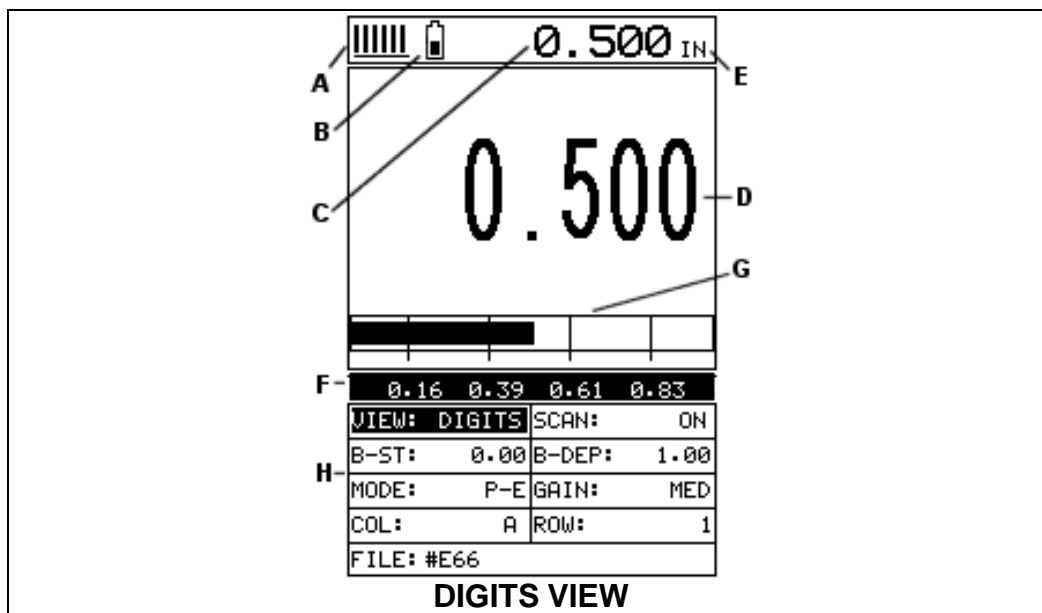

DIGITS

The Digits view is a basic digital thickness gauge look and feel. The larger digits make it much easier for the operator to monitor the thickness readings. The Scan Bar has also been added to the Digits view to provide the user with yet another visual tool for easily monitoring changes in thickness readings due to internal flaws or defects.

The following is a list of the viewable features on the display:

- A) **Stability of Reading Indicator** – Indicates the stability of the return echo on a scale of 1 to 6 – the solid bars displayed in the figure above indicate a repeatable

signal. If the **MMX-7** is displaying a reading from memory, the repeatability indicator will be replaced by the text “**MEM**”.

- B) **Battery life indicator** – Fully charged batteries will appear filled in solid. Note: The diagram shows the batteries at approximately 50%.
- C) **Thickness reading** – Digital readout of thickness (inches or millimeters).
- D) **Large Digits** – Large readout of thickness (inches or millimeters).
- E) **Units Label** – Display’s the current unit of measurement (inches or millimeters).
- F) **Measurement Labels** – The measurement labels are calculated and displayed based on where the left side of the display has been set (**Delay**), and the overall viewable area (**Width**) of the display. Note: The gray hash marks break the display up into 5 segments, or quadrants. The measurement labels correspond to the measurement at each hash mark.
- G) **Scan Bar** – The scan bar corresponds directly with thickness represented by the horizontal labels on the on the display. As you can see from the diagram above, the filled horizontal bar is displayed at .500”. This display can be very useful when scanning materials in either B-Scan or Digits display views. It is much easier to watch and notice deflections for flaws and pits using the scan bar, rather than trying to notice changes in the digital value. If the user is scanning a pipe, for instance, and passes over a pit during the process, the scan bar will quickly deflect and alarm the user to go back and search for the defect.
- H) **Hot Menus** - Each of the fields located under the display are called the **Hot Menu Fields**. These fields allow quick control of some of the fine adjustments needed to control the display settings, measurement modes, and grid memory control. All of these fields can be adjusted without having to activate the tabbed menu items and searching through a variety of menus to make adjustments.

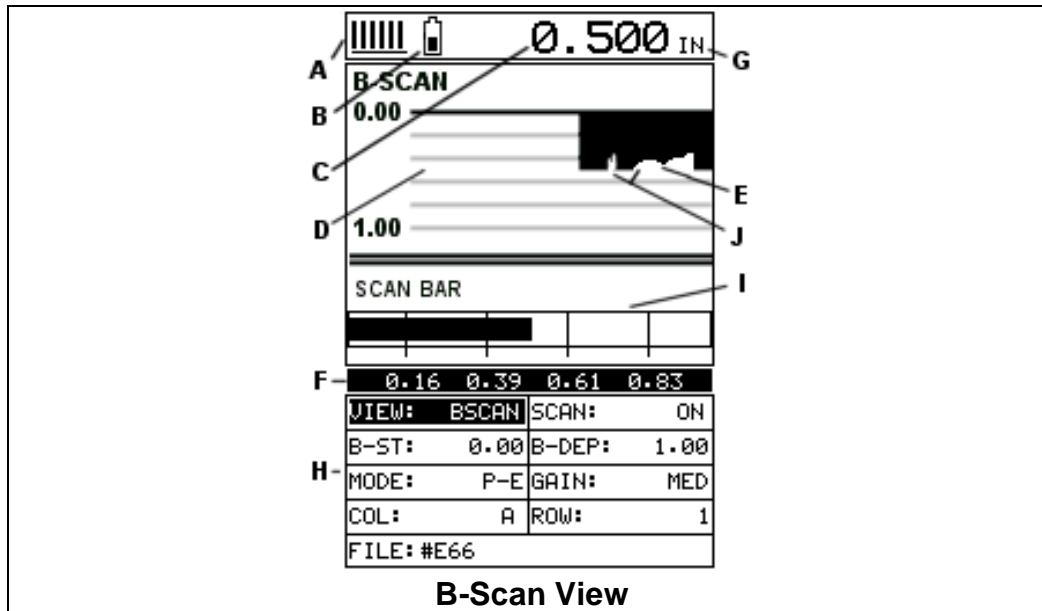

B-Scan

The B-Scan displays a time based cross section view of test material. This view is commonly used to display the contour of the blind, or underside, surface of a pipe or tank application. It is very similar to a fish finder. If a flaw or pit is located during a scan, the B-Scan will draw the pit on the screen. The solid black rectangle in the diagram at location E represents the cross section, or side view of the material. You will notice that the overall thickness of the material is .500", and the display range is 0.00" to 1.00" respectively. The B-Scan view draws at a rate of 15 seconds per screen from right to left. Also notice at location J, the pits and corroded bottom surface of the material.

It's important to note that the measurement range on the display be set wide enough, so that the maximum thickness of the material can be viewed on the display. Using the diagram above, if the material thickness was actually 1.75", the underside of the material would not be viewable according to the current range at 0.00" – 1.00". All the user would see is a black screen from 0.00" – 1.00" with no view of the bottom contour at 1.75".

The following is a list of the viewable features on the display:

- Stability of Reading Indicator** – Indicates the stability of the echo signal on a scale of 1 to 6 – the solid bars displayed in the figure above indicate a repeatable signal. If the *MMX-7* is displaying a reading from memory, the repeatability indicator will be replaced by the text "MEM".
- Battery life indicator** – Fully charged batteries will appear filled in solid. Note: The diagram shows the batteries at approximately 50%.
- Thickness reading** – Digital readout of thickness (inches or millimeters).

- D) **B-Scan Display Area** – This is the area representing where the B-Scan will be drawn. Notice the range of the area in the diagram at 0.00” – 1.0” respectively.
- E) **Displayed B-Scan** – Graphical presentation of the cross section, or side view of the test material. The top, or accessible side of the material represented as 0.00”, and the bottom, or blind surface at .500”. You will notice the contour in the B-Scan, indicating a very corroded bottom surface. The B-Scan is displayed from right to left at a rate of 15 screens per second.
- F) **Measurement Labels** – The measurement labels are calculated and displayed based on where the left side of the display has been set (**Delay**), and the overall viewable area (**Width**) of the display. Note: The gray hash marks break the display up into 5 segments, or quadrants. The measurement labels correspond to the measurement at each hash mark.
- G) **Units Label** - Display’s the current unit of measurement (inches or millimeters).
- H) **Hot Menus** - Each of the fields located under the B-Scan display are called the **Hot Menu Fields**. These fields allow quick control of some of the fine adjustments needed to control the display settings, measurement modes, and grid memory control. All of these fields can be adjusted without having to activate the tabbed menu items and searching through a variety of menus to make adjustments.
- I) **Scan Bar** – The scan bar corresponds directly with thickness represented by the horizontal labels on the on the display. As you can see from the diagram above, the filled horizontal bar is displayed at .500”. This display can be very useful when scanning materials in either B-Scan or Digits display views. It is much easier to watch and notice deflections for flaws and pits using the scan bar, rather than trying to notice changes in digital values. If the user is scanning a pipe, for instance, and passes over a pit in the process, the scan bar will quickly deflect and alarm the user to go back and search for the defect.
- J) **Contour (blind surface)** – A view of the B-Scan displaying the blind side surface contour of the material.

7.3 Adjusting the B-Scan Start (B-ST) & Depth (B-DEP)

In order to use the B-Scan and Scan Bar features of the *MMX-7* effectively, the starting depth and overall depth must be setup correctly. This can be adjusted using the **B-ST (start)** and the **B-DEP (depth)** features of the *MMX-7*. The **B-ST** refers to the starting depth or thickness value displayed. Example: If you want your B-Scan or Scan Bar to start at a zero thickness value, then **B-ST** must be set to 0.000”. If you want the B-Scan and Scan Bar to start displaying at .125”, then **B-ST** must be set to .125”. **B-DEP** represents overall viewable thickness range being tested. Example: If your measuring tank walls with a total thickness of .300”, and your **B-ST** has been set to 0.000”, you might consider setting your **B-DEP** value to something like 0.400” to cover the entire thickness range being tested. You might also consider **B-DEP** as a zoom feature for both the B-Scan and Scan Bar. Why? Because the larger the overall thickness range view (**B-DEP**), the smaller the noticeable shifts in the Scan Bar and B-Scan presentation. Therefore, it’s best to set the **B-ST** and **B-DEP** to reasonable values that zoom in and optimize your graphic representations.

Overall range (B-DEP)

Once again, just to reiterate, B-DEP is the overall viewable thickness range being tested. This should be set to a value slightly larger than the expected maximum range being measured. The procedures to adjust the overall thickness range viewed (**B-DEP**) are outlined below:

Adjusting the Depth (B-DEP) using the Hot Menu

1.00	
OK	ESC
0.16 0.39 0.61 0.83	
VIEW: DIGITS	SCAN: ON
B-ST: 0.00	B-DEP: 1.00
MODE: P-E	GAIN: MED
COL: A	ROW: 1
FILE: #E66	

- 1) Press the **MEAS** key once to activate measure menu items. Press the **MEAS** key multiple times to move right and the **ESC** key multiple times to move left, until the **B-DEP** cell is highlighted.
- 2) Press the **UP**, **DOWN**, **LEFT**, and **RIGHT** arrow keys to scroll the highlighted value.
- 3) **Alternatively**, press the **ENTER** key to display the **Digits Edit Box**.
- 4) Press the **UP** and **DOWN** arrow keys to scroll the highlighted value.
- 5) Press the **LEFT** and **RIGHT** arrow keys to scroll the digit locations.
- 6) Repeat steps **4 & 5** until the **B-DEP** value is correctly displayed.
- 7) Press the **OK** key to return to the measurement screen, or **ESC** to cancel entering the **B-DEP**.

The user can also access and adjust the **B-DEP** range from the tabbed menus. However, this method is a more tedious than making the adjustments using the Hot Menu. The procedure using the tabbed menu is outlined below:

Adjusting the Overall Depth (B-DEP) using the Tabbed Menus

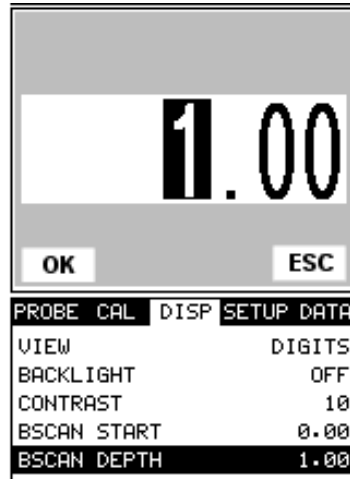

- 1) Press the **MENU** key once to activate the menu items tab. Press the **MENU** key multiple times to tab right, and the **ESC** key multiple times to tab left, until the **DISP** menu is highlighted and displaying the submenu items.
- 2) Use the **UP** and **DOWN** arrow keys to scroll through the sub menu items until **BSCAN DEPTH** is highlighted.
- 3) Press the **LEFT** and **RIGHT** arrow keys to scroll the value. When the correct width is being displayed, **proceed to step 8**.
- 4) **Alternatively**, press the **ENTER** key to display the **Digits Edit Box**.
- 5) Press the **UP** and **DOWN** arrow keys to scroll the highlighted value.
- 6) Press the **LEFT** and **RIGHT** arrow keys to scroll the digit locations.
- 7) Repeat steps **5 & 6** until the **Bscan Depth** value is correctly displayed.
- 8) Press the **OK** key to set the **Bscan Depth** and return to the menu screen, or **ESC** to cancel entering the **Bscan Depth**.

9) Finally, press the **MEAS** key to return to the measurement screen and begin taking readings.

Starting depth (B-ST)

The starting **B-ST**, or starting depth, is the starting thickness value. Often times this value will simply be set to zero in order to start measuring at 0.000". The only time this value will be set to something other than zero, is if the user needs to zoom in even closer. When will this be the case? If the user is testing a material that's 1 inch in thickness and knows that the potential corrosion is only on the back surface of the material and not possibly deeper than .200". In this case, the user may wish to set the B-ST at .700" to zoom in closer to the actual area being tested. In turn, the B-DEP might be set at 1.100" in order to cover the entire range respectively. This will offer the user better resolution for both the B-Scan and Scan Bar graphical presentations.

Note: Once the range is set, it will remain the same for all the views respectively.

The procedures to adjust the starting depth (**B-ST**) are outlined below:

Adjusting the Starting Depth (B-ST) using the Hot Menu

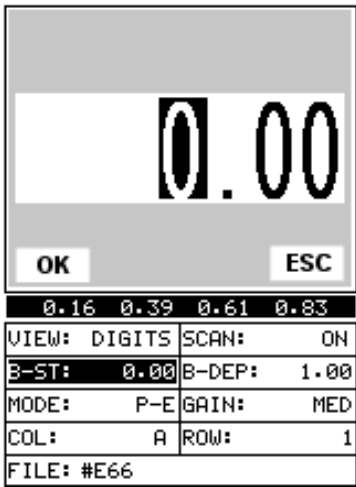

The screenshot shows a menu with a large display of '0.00' at the top. Below it are 'OK' and 'ESC' buttons. A row of values '0.16 0.39 0.61 0.83' is visible. The menu items are as follows:

VIEW: DIGITS	SCAN: ON
B-ST: 0.00	B-DEP: 1.00
MODE: P-E	GAIN: MED
COL: A	ROW: 1
FILE: #E66	

1) Press the **MEAS** key once to activate measure menu items. Press the **MEAS** key multiple times to move right and the **ESC** key multiple times to move left, until the **B-ST** cell is highlighted.

- 2) Press the **UP**, **DOWN**, **LEFT**, and **RIGHT** arrow keys to scroll the highlighted value.
- 3) **Alternatively**, press the **ENTER** key to display the **Digits Edit Box**.
- 4) Press the **UP** and **DOWN** arrow keys to scroll the highlighted value.
- 5) Press the **LEFT** and **RIGHT** arrow keys to scroll the digit locations.
- 6) Repeat steps **4 & 5** until the **B-ST** value is correctly displayed.
- 7) Press the **OK** key to return to the measurement screen, or **ESC** to cancel entering the **B-ST**.

The user can also access and adjust the **B-ST** from the tabbed menus. However, this method is more tedious than making the adjustments using the Hot Menu. The procedure using the tabbed menu is outlined below:

Adjusting the Starting Depth (B-ST) using the Tabbed Menu

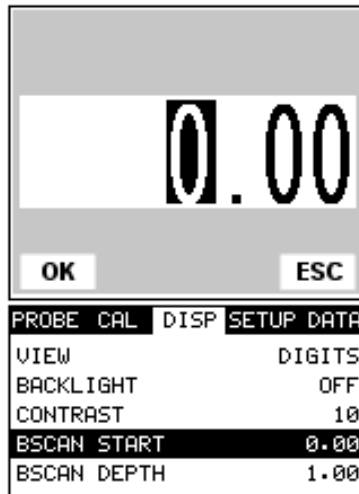

- 1) Press the **MENU** key once to activate the menu items tab. Press the **MENU** key multiple times to tab right, and the **ESC** key multiple times to tab left, until the **DISP** menu is highlighted and displaying the submenu items.
- 2) Use the **UP** and **DOWN** arrow keys to scroll through the sub menu items until **BSCAN START** is highlighted.

- 3) Press the **LEFT** and **RIGHT** arrow keys to scroll the value. When the correct **Bscan Start** is being displayed, **proceed to step 8**.
- 4) **Alternatively**, press the **ENTER** key to display the **Digits Edit Box**.
- 5) Press the **UP** and **DOWN** arrow keys to scroll the highlighted value.
- 6) Press the **LEFT** and **RIGHT** arrow keys to scroll the digit locations.
- 7) Repeat steps **5 & 6** until the **Bscan Start** number is correctly displayed.
- 8) Press the **OK** key to set the **Bscan Start** and return to the menu screen, or **ESC** to cancel entering the **Bscan Start**.
- 9) Finally, press the **MEAS** key to return to the measurement screen and begin taking readings.

7.4 Gain

The gain, or amplification of the return echoes, can be adjusted in the **MMX-7** to accommodate a variety of applications. The setting of the gain is crucial in order to obtain valid readings during the measurement process. Too much gain may result in erroneous measurements, by detecting on noise rather than the actual material back wall itself. Not enough gain may result in intermittent detection. It may also result in lack of detection on internal flaws, pits, or porosity. The gain can easily be compared to the volume control of a home stereo system. If you turn it up too much, you can't hear the music clearly. If it's turned down too much, you can't hear it at all.

The **MMX-7** has three gain settings (**low, med, high**). **Note:** The **MMX-7** has been optimized for the **MED** gain setting for all common performance racing applications. It should be operated in this mode as standard. However, some applications may require the low or high gain setting. When? The low setting may be necessary for certain cast aluminum materials, or very extremely granular cast iron materials. How do I know when to lower the gain? If the reading becomes sporadic and won't settle down or resolve on a thickness value, the user can assume that the material is either very noisy aluminum, or granular cast iron. This would be a good time to change the **MMX-7** to low gain setting and see if the reading settles down and become stable.

How do I know when to increase the gain? Often times the user will be trying to measure a material that is hard to penetrate or pass sound through. This may be due to the material type, or overall thickness of the material. When a material is hard to pass sound through because of the thickness or general make-up, it would be a good time to consider switching the **MMX-7** into a high gain setting. In any case, the selectable gain settings offer the user some additional options to resolve application issues.

Note: When the echo-echo thru-paint measurement mode is selected, the gain manual gain feature is disabled and grayed out in the menu items. In this mode, the **MMX-7** switches to an automatic gain mode (**AGC**), that optimizes the gain setting automatically in the hardware of the **MMX-7**.

The procedures to adjust the **Gain** are outlined below:

Adjusting the Gain using the Hot Menus

VIEW:	BSCAN	SCAN:	ON
B-ST:	0.00	B-DEP:	1.00
MODE:	P-E	GAIN:	MED
COL:	A	ROW:	1
FILE: #E66			

- 1) Press the **MEAS** key once to activate measure menu items. Press the **MEAS** key multiple times to move right, and the **ESC** key multiple times to move left until the **GAIN** cell is highlighted.
- 2) Press the **UP**, **DOWN**, **LEFT**, and **RIGHT** arrow keys to scroll the highlighted value.
- 3) **Alternatively**, press the **ENTER** key to display the **Digits Edit Box**.
- 4) Press the **UP** and **DOWN** arrow keys to scroll the highlighted value.
- 5) Press the **LEFT** and **RIGHT** arrow keys to scroll the digit locations.
- 6) Repeat steps **4 & 5** until the **GAIN** value is correctly displayed.
- 7) Press the **OK** key to return to the measurement screen, or **ESC** to cancel entering the **GAIN**.

The user can also access and adjust the gain from the tabbed menus. However, this method is more tedious than making the adjustments using the **Hot Menu**. The procedure using the tabbed menus is outlined below:

Adjusting the Gain using the Tabbed Menu

PROBE	CAL	DISP	SETUP	DATA
ZERO	TRANSDUCER			
TYPE				1
GAIN				MED
MEASURE	MODE			P-E

- 1) Press the **MENU** key once to activate the menu items tab. Press the **MENU** key multiple times to tab right, and the **ESC** key multiple times to tab left, until the **PROBE** menu is highlighted and displaying the submenu items.
- 2) Use the **UP** and **DOWN** arrow keys to scroll through the sub menu items until **GAIN** is highlighted.
- 3) Press the **LEFT** and **RIGHT** arrow keys to scroll the value. When the correct **Gain** is being displayed, **proceed to step 8**.
- 4) **Alternatively**, press the **ENTER** key to display the **Digits Edit Box**.
- 5) Press the **UP** and **DOWN** arrow keys to scroll the highlighted value.
- 6) Press the **LEFT** and **RIGHT** arrow keys to scroll the digit locations.
- 7) Repeat steps **5 & 6** until the **Gain** value is correctly displayed.
- 8) Press the **OK** key to set the **Gain** and return to the menu screen, or **ESC** to cancel entering the **Gain**.
- 9) Finally, press the **MEAS** key to return to the measurement screen and begin taking readings.

CHAPTER EIGHT THRU PAINT MEASUREMENT TECHNIQUE

8.1 Introduction to Thru Paint Measurement

The principle behind thru paint measurement is by measuring the time between two backwall echoes returning from the test material. Since both of these backwall echoes travel the same path through the paint or coating, the thickness of the coating is subtracted out of the measurement so that only the actual material thickness can be measured. This feature saves the user a great deal of time scraping and removing the coating from tanks and pipes during the inspection process.

The primary purpose of thru paint measurement is to determine actual or overall material thickness by eliminating the coating thickness. Thru paint mode cannot be used for flaw or pit detection. Therefore, inspectors may need to use echo-echo thru paint mode in conjunction with the standard pulse-echo flaw detection mode for some applications. Chassis tubing inspectors and sanctioning bodies will use the echo-echo mode for tubing with powder coatings, and pulse-echo mode for tubing without coating. The combination of using both modes is ideal for the advanced inspectors needs.

8.2 Using Thru Paint Mode

The first thing to note in this section, is that by selecting the transducer type from the list of probes stored in the **MMX-7**, a basic echo-echo thru paint configuration is recalled from memory. Each of the transducers in the list contain pre-configured echo-echo settings. The standard transducer that will be used for the racing industry is a ¼" 5MHz high damped transducer (**1/4IN – 5.0MHZ HD**). This is the recommended transducer for this industry and should be used for thru paint applications. Once the transducer type has been selected and the appropriate calibration procedure completed, the **MMX-7** can toggle between **pulse-echo** (flaws & pits), and **echo-echo** (thru paint) modes by simply pressing the **MULTI MODE** key located on the keypad. Refer to page 28 for additional information.

The **MMX-7** can also be configure for thru paint applications by selecting a factory setup stored in the list of setups in the **MMX-7**. Refer to page 75 for information on recalling a setup. Once either the transducer type or setup has been selected, the inspector is ready to begin making measurements.

CHAPTER NINE ADDITIONAL FEATURES OF THE MMX-7

9.1 High Speed Scan

The High Speed Scan feature of the *MMX-7* increases the overall sample rate from the standard 4 measurements a second to 32 measurements a second. This feature enables a user to make scanned passes over an arbitrary length of the test material, while still maintaining a reasonable representation of thickness over the scanned area or region. This feature is typically used to speed up the inspection.

The procedure to use the **SCAN MODE** feature is outlined below:

Using the Scan Mode

UTIL	XFER
SCAN MODE	OFF
ALARM STATUS	ON
ALARM LO LIMIT	0.000
ALARM HI LIMIT	0.000

- 1) Press the **MENU** key once to activate the menu items tab. Press the **MENU** key multiple times to tab right and the **ESC** key multiple times to tab left until the **UTIL** menu is highlighted and displaying the submenu items.
- 2) Use the **UP** and **DOWN** arrow keys to scroll through the sub menu items until **SCAN MODE** is highlighted.
- 3) Use the **LEFT** and **RIGHT** arrow keys to toggle the **SCAN MODE** on/off.
- 4) Press the **MEAS** key to return to the measurement screen.

9.2 Alarm Mode

The **Alarm Mode** feature of the *MMX-7* provides the user with a method of setting tolerances, or limits, for a particular application requirement. This feature may be used for a variety of applications to verify the material is within the manufacturer specifications. There are two limits, or alarm values, that can be setup in the *MMX-7* – **ALARM LO LIMIT** and **ALARM HI LIMIT**. However, the user may choose to

activate and utilize only one of the limit values, depending on their specific application requirements. The procedures to use the **ALARM MODE** feature are outlined below:

UTIL XFER	
SCAN MODE	OFF
ALARM STATUS	ON
ALARM LO LIMIT	0.000
ALARM HI LIMIT	0.000

UTIL XFER	
SCAN MODE	OFF
ALARM STATUS	ON
ALARM LO LIMIT	0.000
ALARM HI LIMIT	0.000

UTIL XFER	
SCAN MODE	OFF
ALARM STATUS	ON
ALARM LO LIMIT	0.000
ALARM HI LIMIT	0.000

UTIL MENU – ALARM MODE

Toggle Alarm Status (on/off)

UTIL XFER	
SCAN MODE	OFF
ALARM STATUS	ON
ALARM LO LIMIT	0.000
ALARM HI LIMIT	0.000

- 1) Press the **MENU** key once to activate the menu items tab. Press the **MENU** key multiple times to tab right, and the **ESC** key multiple times to tab left, until the **UTIL** menu is highlighted and displaying the submenu items.
- 2) Use the **UP** and **DOWN** arrow keys to scroll through the sub menu items until **ALARM STATUS** is highlighted.

- 3) Use the **LEFT** and **RIGHT** arrow keys to toggle the **ALARM STATUS** on/off/audible.
- 4) Continue on to the next section “**Setting the Alarm Lo Limit**”.

Setting the Alarm LO Limit

UTIL	XFER
SCAN MODE	OFF
ALARM STATUS	ON
ALARM LO LIMIT	0.000
ALARM HI LIMIT	0.000

- 1) Assuming the **ALARM STATUS** is **ON**, use the **UP** and **DOWN** arrow keys to scroll through the sub menu items until **ALARM LO LIMIT** is highlighted.
- 2) Press the **LEFT** and **RIGHT** arrow keys to scroll the value. When the correct alarm value is being displayed, **proceed to step 7**.
- 3) **Alternatively**, press the **ENTER** key to display the **Digits Edit Box**.
- 4) Press the **UP** and **DOWN** arrow keys to scroll the highlighted value.
- 5) Press the **LEFT** and **RIGHT** arrow keys to scroll the digit locations.
- 6) Repeat steps **4 & 5** until the **ALARM LO** value is correctly displayed.
- 7) If only one limit will be used, press the **MEAS** key to return to the measurement screen and begin taking readings. Otherwise, continue on to set the **ALARM HI LIMIT**.

Setting the Alarm HI Limit

UTIL	XFER
SCAN MODE	OFF
ALARM STATUS	ON
ALARM LO LIMIT	0.000
ALARM HI LIMIT	0.000

- 1) Assuming the **ALARM STATUS** is **ON**, use the **UP** and **DOWN** arrow keys to scroll through the sub menu items until **ALARM HI LIMIT** is highlighted.
- 2) Press the **LEFT** and **RIGHT** arrow keys to scroll the value. When the correct alarm value is being displayed, **proceed to step 8**.
- 3) **Alternatively**, press the **ENTER** key to display the **Digits Edit Box**.
- 4) Press the **UP** and **DOWN** arrow keys to scroll the highlighted value.
- 5) Press the **LEFT** and **RIGHT** arrow keys to scroll the digit locations.
- 6) Repeat steps **4 & 5** until the **ALARM HI** value is correctly displayed.
- 7) Press the **OK** key to set the **ALARM HI** value and return to the menu screen, or **ESC** to cancel entering the **ALARM HI** value.
- 8) Press the **MEAS** key to return to the measurement screen and begin taking readings.

CHAPTER TEN DATA STORAGE – SETUP, EDIT, & VIEW FILES

10.1 Introduction to Grid (spreadsheet) format

Data is stored in the **MMX-7** in a spreadsheet like format called a **GRID**. A **GRID** is simply a table of readings. The location in a grid is specified by giving a row and column coordinate. The rows are numbered from 1 to 250 and the columns are labeled from A to ZZ (250 Rows & 52 Columns).

Multiple grids can be created and stored until the **MMX-7**'s memory is full. If the user attempts to store a grid in the **MMX-7** when the memory is full, the **MMX-7** will respond with an error message indicating that the memory is unable to store the new grid.

The **MMX-7** can store a total of **12,000 readings** with a corresponding screenshot of the **DIGITS** or **B-SCAN** views with every reading. The screenshot stored with the reading will depend on what view the **MMX-7** was in at the time it was saved. For example, If the view is **B-SCAN**, then a **B-Scan** will be saved with the reading.

Important Note: For the duration of this chapter, all references to **GRIDS** should also be considered references to **FILES**.

10.2 Creating a new Grid (File)

Important Note: This entire section is a step by step guide to successfully create a grid. The instructions must be used in the sequential order specified, as follows:

Creating a Grid Name

NEW GRID	
NAME:	
NOTE:	
TOP LEFT:	A01
LOWER RIGHT:	D3
INCR. DIR:	EAST
CREATE NEW GRID?	
SETUP	DATA UTIL %FER
NEW	
EDIT	
OPEN	
DELETE ONE GRID	
DELETE ALL GRIDS	

- 1) Press the **MENU** key once to activate the menu items tab. Press the **MENU** key multiple times to tab right, and the **ESC** key multiple times to tab left, until the **DATA** menu is highlighted and displaying the submenu items.
- 2) Use the **UP** and **DOWN** arrow keys to scroll through the sub menu items until **NEW** is highlighted.
- 3) Press the **ENTER** key to display the new **Grid Edit Box**.
- 4) Use the **UP** and **DOWN** arrow keys to scroll through the new **Grid List Items** until **NAME** is highlighted.
- 5) Press the **ENTER** key to activate the **Alpha Edit Box**.



- 6) Use the **UP**, **DOWN**, **LEFT**, & **RIGHT** arrow keys to highlight the appropriate alpha characters.
- 7) Press the **ENTER** key to select a character and advance to the next field of the **Grid Name**.
- 8) Use the **CLR** key to backspace if necessary.
- 9) Repeat steps **6 - 8** until the **Grid Name (File Name)** is completed.
- 10) Press the **OK** key to save the **Grid Name** and return to the **Grid List Items** menu, or **ESC** to cancel entering the **Grid Name (File Name)**.

Creating a Grid Note

NEW GRID	
NAME:	
NOTE:	
TOP LEFT:	A01
LOWER RIGHT:	D3
INCR. DIR:	EAST
CREATE NEW GRID?	
SETUP DATA UTIL XFER	
NEW	
EDIT	
OPEN	
DELETE ONE GRID	
DELETE ALL GRIDS	

- 1) Use the **UP** and **DOWN** arrow keys to scroll through the new **Grid List Items** until **NOTE** is highlighted.
- 2) Press the **ENTER** key to activate the **Alpha Edit Box**.

0123456789
! " # \$ % & ' ()
ABCDEFGHIJ
KLMNOPQRST
UVWXYZ
█
SETUP DATA UTIL XFER
NEW
EDIT
OPEN
DELETE ONE GRID
DELETE ALL GRIDS

- 3) Use the **UP, DOWN, LEFT, & RIGHT** arrow keys to highlight the appropriate alpha characters.
- 4) Press the **ENTER** key to select a character and advance to the next field of the **Grid Note**.

- 5) Use the **CLR** key to backspace if necessary.
- 6) Repeat steps **3** through **5** until the **Grid Note** is completed.
- 7) Press the **OK** key to save the **Grid Note** and return to the **Grid List Items** menu, or **ESC** to cancel entering the **Grid Note**.

Setting the Coordinates of the Grid

Note: A grid is defined by using coordinates to define the **Top Left** and the **Bottom Right** corners of the grid. Alpha coordinates are horizontal across the top, and numeric coordinates are vertical down the side. Therefore, to define the top left corner of the grid, there will be an (X,Y) coordinate. Where X is an alpha column location across the top and Y is a numeric row location down the side. Use the same logic when choosing the lower right corner.

Setting the Top Left Coordinate

NEW GRID	
NAME:	
NOTE:	
TOP LEFT:	A01
LOWER RIGHT:	D3
INCR. DIR:	EAST
CREATE NEW GRID?	
SETUP	DATA UTIL XFER
NEW	
EDIT	
OPEN	
DELETE ONE GRID	
DELETE ALL GRIDS	

- 1) Use the **UP** and **DOWN** arrow keys to scroll through the new **Grid List Items** until **TOP LEFT** is highlighted.

- 2) Press the **ENTER** key to activate the **Coordinate Edit Box**.

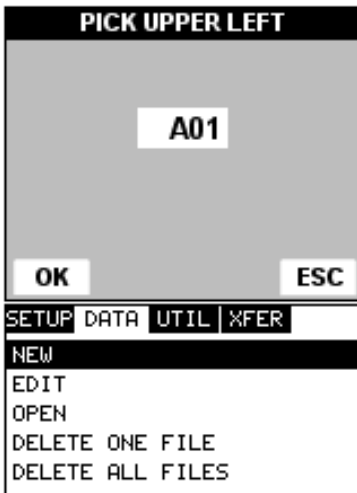

- 3) Use the **LEFT, & RIGHT** arrow keys to scroll the **Columns**, and the **UP, DOWN** arrow keys to scroll the **Rows**.
- 4) Press the **OK** key to select the coordinate and return to the **Grid List Items** screen, or **ESC** to cancel the selection and return to the **Grid List Items** menu.

Setting the Lower Right Coordinate

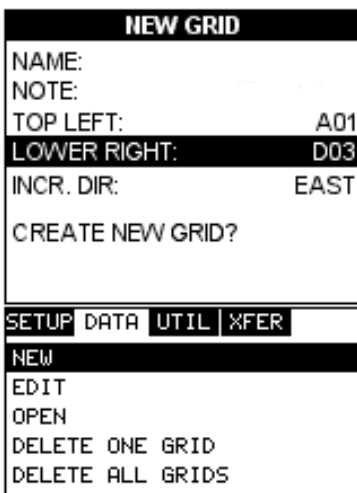

- 1) Use the **UP** and **DOWN** arrow keys to scroll through the new **Grid List Items** until **LOWER RIGHT** is highlighted.

- 2) Press the **ENTER** key to activate the **Coordinate Edit Box**.

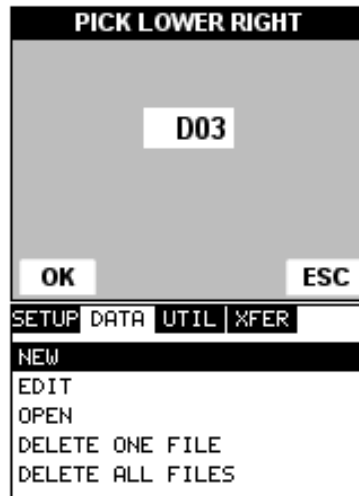

- 3) Use the **LEFT, & RIGHT** arrow keys to scroll the **Columns**, and the **UP, & DOWN** arrow keys to scroll the **Rows**.
- 4) Press the **OK** key to select the coordinate and return to the **Grid List Items** screen, or **ESC** to cancel the selection and return to the **Grid List Items** menu.

Note: If there is not enough memory available to create the grid, an error message box “**NOT ENOUGH MEMORY**“ will be displayed. Press the **OK** or **ESC** key to return to the **Grid List Items** menu. It may be necessary to free some memory in the **MMX-7** at this time. Refer to page 68 for more information on **Deleting a Grid**.

Selecting the Auto Increment Direction

The **Auto Increment** feature gives the user the ability to specify which direction to advance the cursor after storing a reading.

NEW GRID	
NAME:	
NOTE:	
TOP LEFT:	A01
LOWER RIGHT:	D3
INCR. DIR:	WEST
CREATE NEW GRID?	
SETUP DATA UTIL XFER	
NEW	
EDIT	
OPEN	
DELETE ONE GRID	
DELETE ALL GRIDS	

- 5) Use the **UP** and **DOWN** arrow keys to scroll through the new **Grid List Items** until **INCR. DIR** is highlighted.
- 6) Use the **LEFT & RIGHT** arrow keys to toggle the **Increment** direction **NONE, NORTH, EAST, SOUTH, or WEST**.
- 7) When the correct **Increment** direction is displayed, continue on to the next section "**Saving the Grid**".

Saving a Grid

Once all the parameters are set, the user has the option of saving or canceling the new grid.

NEW GRID	
NAME:	
NOTE:	
TOP LEFT:	A01
LOWER RIGHT:	D3
INCR. DIR:	EAST
CREATE NEW GRID?	
SETUP	DATA UTIL XFER
NEW	
EDIT	
OPEN	
DELETE ONE GRID	
DELETE ALL GRIDS	

- 1) Use the **UP** and **DOWN** arrow keys to scroll through the new **Grid List Items** until **CREATE NEW GRID?** is highlighted.
- 2) Press the **ENTER** key to accept the grid parameters, and activate the confirmation screen.

CONFIRM	
CREATE	
NEW	?
GRID?	
OK	ESC
SETUP	DATA UTIL XFER
NEW	
EDIT	
OPEN	
DELETE ONE FILE	
DELETE ALL FILES	

- 3) Press the **OK** key to save the **New Grid**, or the **ESC** key to cancel the **New Grid** setup and return to the **DATA** menu.

- 4) Press the **MEAS** key to return to the measurement screen and begin storing readings.

10.3 Storing a reading

Now that a grid has been created, it's time to make some measurements and store the readings. The following procedures outline this process:

Storing a Reading

VIEW: DIGITS	SCAN: OFF	VIEW: DIGITS	SCAN: OFF
B-ST: 0.00	B-DEP: 1.00	B-ST: 0.00	B-DEP: 1.00
MODE: P-E	GAIN: MED	MODE: P-E	GAIN: MED
COL: A	ROW: 1	COL: A	ROW: 1
FILE: BOILER #E56		FILE: BOILER #E56	

- 1) Press the **MEAS** key once to activate measure menu items. Press the **MEAS** key multiple times to move right and the **ESC** key multiple times to move left until the either the **COL** or **ROW** cell is highlighted.

	A	B	C
1	0.027	0.027	0.027
2	0.027	0.999	0.027
3	0.027	0.027	0.196
4	0.027	0.027	0.027

- 2) Press the **ENTER** key to display the **Grid View Box**.
- 3) Press the **UP**, **DOWN**, **LEFT**, and **RIGHT** arrow keys to scroll the target cell cursor to the desired storage location.
- 5) Press the **ENTER** key to save the current reading in the highlighted cell location.

6) Abort the **Grid View Box** by pressing the **MEAS** key at any time.

Note: Every time a reading is saved to memory, a picture of the display is automatically saved with the reading.

10.4 Viewing stored readings

It is sometimes necessary to go back and view the stored readings and waveforms using the **MMX-7** without a PC. The following procedures outline this process:

Viewing Stored Readings & B-Scans

VIEW: DIGITS	SCAN: OFF	VIEW: DIGITS	SCAN: OFF
B-ST: 0.00	B-DEP: 1.00	B-ST: 0.00	B-DEP: 1.00
MODE: P-E	GAIN: MED	MODE: P-E	GAIN: MED
COL: A	ROW: 1	COL: A	ROW: 1
FILE: BOILER #E56		FILE: BOILER #E56	

1) Press the **MEAS** key once to activate measure menu items. Press the **MEAS** key multiple times to move right and the **ESC** key multiple times to move left until the **COL** or **ROW** cell is highlighted.

	A	B	C
1	0.027	0.027	0.027
2	0.027	0.999	0.027
3	0.027	0.027	0.196
4	0.027	0.027	0.027

2) Press the **ENTER** key to display the **Grid View Box**.

3) Press the **UP**, **DOWN**, **LEFT**, and **RIGHT** arrow keys to scroll the stored readings and corresponding display view. Notice as the cursor is moved to a different cell, the display will be updated with the display view saved with the reading.

- 4) The user may opt to clear a specific reading and save a new one at any time. Press the **CLR** key in the appropriate cell location to clear the reading, take a new measurement, and press the **OK** key to save the new reading.
- 5) Abort the **Grid View Box** by pressing the **MEAS** key at any time.

10.5 Deleting Grids (Files)

Deleting One or All Files from Memory

Deleting One File

```
PROBE CAL DISP SETUP DATA
NEW
EDIT
OPEN
DELETE ONE FILE
DELETE ALL FILES
```

- 1) Press the **MENU** key once to activate the menu items tab. Press the **MENU** key multiple times to tab right and the **ESC** key multiple times to tab left until the **DATA** menu is highlighted and displaying the submenu items.
- 2) Use the **UP** and **DOWN** arrow keys to scroll through the sub menu items until **DELETE ONE FILE** is highlighted.

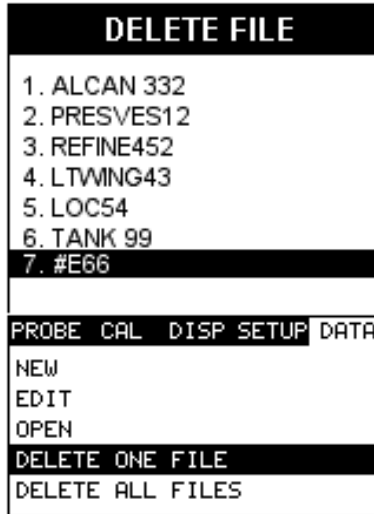

- 3) Press the **ENTER** key to display the **Grid List Box**.
- 4) Use the **UP** and **DOWN** arrow keys to scroll through the stored **Grids** until the target **File** to delete is highlighted.
- 5) Press the **OK** key to delete the **File**.
- 6) Press the **MEAS** key to return to the measurement screen.

Deleting All Files



- 1) Press the **MENU** key once to activate the menu items tab. Press the **MENU** key multiple times to tab right and the **ESC** key multiple times to tab left until the **DATA** menu is highlighted and displaying the submenu items.
- 2) Use the **UP** and **DOWN** arrow keys to scroll through the sub menu items until **DELETE ALL FILES** is highlighted.

CONFIRM

**DELETE ALL
FILES AND
READINGS?**

?

OK
ESC

PROBE CAL DISP SETUP DATA

NEW

EDIT

OPEN

DELETE ONE FILE

DELETE ALL FILES

3) Press the **ENTER** key to activate the confirmation screen.

4) Press the **OK** key to delete **All Files** from memory, or the **ESC** key to abort.

5) Press the **MEAS** key to return to the measurement screen.

10.6 Editing a Grid (File)

Once a grid has been created and saved to memory, the user can edit the **Comments** or **Increment Direction** at a later time. The following procedures outline this process:

Editing a Grid

NAME: 427 CHEUY #E66

NOTE:

TOP LEFT: A1

LOWER RIGHT: EE32

INCR. DIR: NONE

SAVE CHANGES?

NAME: 427 CHEUY #E66

NOTE:

TOP LEFT: A1

LOWER RIGHT: EE32

INCR. DIR: NONE

SAVE CHANGES?

PROBE CAL DISP SETUP DATA

NEW

EDIT

OPEN

DELETE ONE FILE

DELETE ALL FILES

- 1) Press the **MENU** key once to activate the menu items tab. Press the **MENU** key multiple times to tab right and the **ESC** key multiple times to tab left until the **DATA** menu is highlighted and displaying the submenu items.
- 2) Use the **UP** and **DOWN** arrow keys to scroll through the sub menu items until **EDIT** is highlighted.
- 3) Press the **ENTER** key to display the **Edit List Box**.
- 4) Use the **UP** and **DOWN** arrow keys to scroll through the **Edit** options until **NOTE** or **INCR. DIR** is highlighted.

Note: If editing the **INCR. DIR**, simply use the **LEFT** or **RIGHT** arrow keys to scroll **NONE**, **NORTH**, **EAST**, **SOUTH**, or **WEST**. Proceed to step 10.



- 5) Press the **ENTER** key to activate the **Alpha Edit box** – Only used when editing the **NOTE**.
- 6) Use the **UP**, **DOWN**, **LEFT**, & **RIGHT** arrow keys to highlight the appropriate alpha characters.
- 7) Press the **ENTER** key to select a character and advance to the next field of the **Comments**.
- 8) Use the **CLR** key to backspace if necessary.

9) Repeat steps **6 - 8** until the **Comments** are completed.



10) Press the **UP** or **DOWN** arrow key to highlight **SAVE CHANGES**, and the **OK** key to activate the confirmation screen.

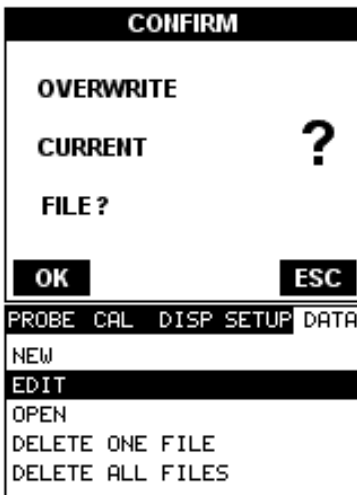

11) Press the **OK** to save the changes or the **ESC** key to cancel editing the grid parameters.

12) Press the **MEAS** key to return to the measurement screen.

10.7 Changing the active grid (File) - Open

The user may have transferred grid templates from a PC to the **MMX-7**, or setup grids using the **MMX-7** at an earlier time. The name of the currently active grid is always displayed at the bottom of the **Hot Menu Items** in measurement mode (refer to photo below). It's not only important to recognize what grid is currently active, but also be able to change the active grid at any time. The following procedures outline this process:

Changing the Active Grid

VIEW: BSCAN	SCAN: ON
B-ST: 0.00	B-DEP: 1.00
MODE: P-E	GAIN: MED
COL: A	ROW: 1
FILE: #E66	

LOAD FILE	
1. ALCAN 332	
2. PRESVES12	
3. REFINE452	
4. LTWING43	
5. LOC54	
6. TANK 99	
7. 427	
PROBE CAL DISP SETUP DATA	
NEW	
EDIT	
OPEN	
DELETE ONE FILE	
DELETE ALL FILES	

- 1) Press the **MENU** key once to activate the menu items tab. Press the **MENU** key multiple times to tab right and the **ESC** key multiple times to tab left until the **DATA** menu is highlighted and displaying the submenu items.
- 2) Use the **UP** and **DOWN** arrow keys to scroll through the sub menu items until **OPEN** is highlighted.
- 3) Press the **ENTER** key to display the **Grid List Box**.
- 4) Use the **UP** and **DOWN** arrow keys to scroll through the grids until the target grid is highlighted.

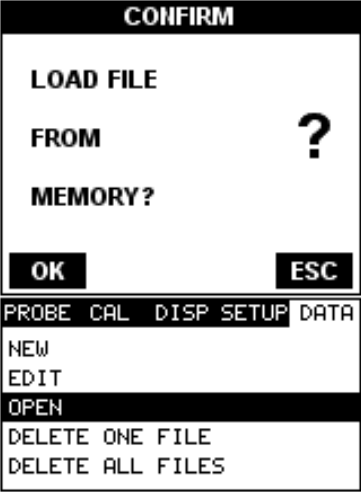

CONFIRM

LOAD FILE

FROM ?

MEMORY?

OK ESC

PROBE CAL DISP SETUP DATA

NEW

EDIT

OPEN

DELETE ONE FILE

DELETE ALL FILES

5) Press the **ENTER** key to activate the confirmation screen.

6) Press the **OK** key to load the grid from memory.

7) Press the **MEAS** key to return to the measure screen.

CHAPTER ELEVEN SETUPS – CREATE, STORE, EDIT, & RECALL

11.1 Introduction to Setups

Often times, users are faced with a variety of tasks and applications that are sometimes similar, but often times very different. With a standard thickness gauge, the user would have to recalibrate for each individual application respectively. With all the features of the **MMX-7**, the number of potential applications also increases based on ability alone. This is primarily in reference to the addition of those very difficult applications, where a standard thickness gauge would not be feasible, or capable of accomplishing the tasks.

The increased number of features and parameters also adds to the overall setup time, or amount of time to set up marginal applications with perfection and understanding. Because of the additional time involved, the **MMX-7** has been equipped with the ability to save these setups to memory and be recalled at any time. The **MMX-7** can store **64 custom setups**. These setups can be bi-directionally transferred to and from a PC. Therefore, the user can save as many setups as necessary for all of the individual applications. This saves a great deal of time and knowledge for future inspections of the same job or project. This feature also eliminates error between two or more users during the setup and calibration process.

11.2 Opening a Setup

The **MMX-7** is loaded with a number of setups from the factory. These setups can be opened, edited, and saved to any one of **64 setup locations**. If a factory setup is written over, the user can simply reload the default factory setups at anytime using the utility software included with the **MMX-7**. The factory setups are general setups **Only**. However, they may serve as an excellent starting point, requiring only minor adjustments to work for custom applications. It is recommended that user customized setups be saved to an empty location, and save the factory setups for the purpose of a general starting point. The following procedures outline how to open factory and custom setups:

Opening a Setup

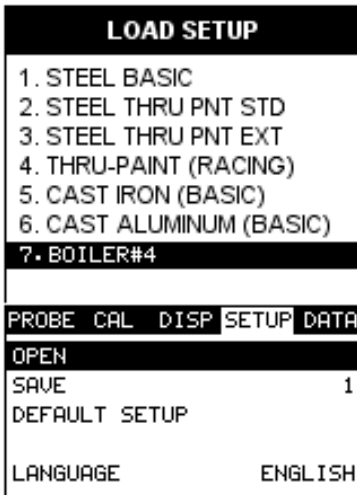

- 1) Press the **MENU** key once to activate the menu items tab. Press the **MENU** key multiple times to tab right and the **ESC** key multiple times to tab left until the **SETUP** menu is highlighted and displaying the submenu items.
- 2) Use the **UP** and **DOWN** arrow keys to scroll through the sub menu items until **OPEN** is highlighted.
- 3) Press the **ENTER** key to display the **Setup List Box**.
- 4) Use the **UP** and **DOWN** arrow keys to scroll through the setups until the target setup is highlighted.

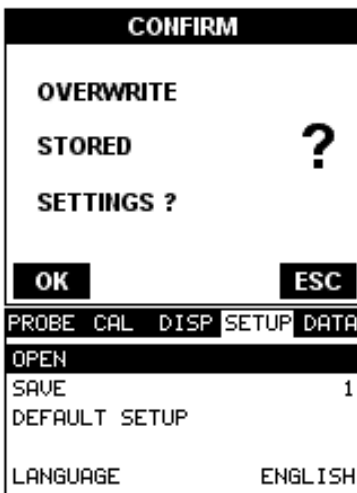

- 5) Press the **ENTER** key to activate the confirmation screen.
- 6) Press the **OK** key to load the setup from memory.
- 7) Press the **MEAS** key to return to the measure screen.

11.3 Saving a Setup

Once the **MMX-7** parameters and features have been adjusted for an application, the user may elect to save these settings to a specific setup location for future use. This can potentially save time and reduce error between users.

It is sometimes necessary to rename a previously saved setup, or add additional comments about a particular setup. The setup name may have been entered incorrectly, or the user needs to use the setup for a completely different project. An inspector's name, or other comments about the project may also be required for additional documentation purposes. The following procedures outline the necessary steps for saving and editing a setup:

Saving the Setup

SAVE SETUP	
NAME:	
NOTE:	
SAVE SETUP?	
PROBE	CAL
DISP	SETUP
DATA	
OPEN	
SAVE	1
DEFAULT	SETUP
LANGUAGE	ENGLISH

- 1) Press the **MENU** key once to activate the menu items tab. Press the **MENU** key multiple times to tab right and the **ESC** key multiple times to tab left until the **SETUP** menu is highlighted and displaying the submenu items.

- 2) Use the **UP** and **DOWN** arrow keys to scroll through the sub menu items until **SAVE** is highlighted.
- 3) Press the **ENTER** key to display the **Save Setup Parameters List Box**.
- 4) Press the **UP** and **DOWN** arrow keys to scroll the **Name** and **Note** parameters.



- 5) When the parameter to edit is highlighted, press the **ENTER** key to activate the **Alpha Edit Box**.
- 6) Use the **UP**, **DOWN**, **LEFT**, and **RIGHT** arrow keys to scroll through the characters, the **ENTER** key to select characters, and the **CLR** key to backspace through the characters, until the **Name** or **Note** fields have been edited.
- 7) Press the **OK** key to return to the **Save Setup Parameters List Box**.
- 8) If both parameters will be edited, **repeat steps 4 – 7**.
- 9) Use the **UP** and **DOWN** arrow keys to scroll to and highlight **SAVE SETUP**.
- 10) Press the **ENTER** key to activate the **Setup List Box**.
- 11) Use the **UP** and **DOWN** arrow keys to scroll through the setups until the target location to save the **Setup** is highlighted.

12) Press the **OK** key to activate the confirmation screen.

13) Press the **OK** key to save the **Setup**, or **ESC** to cancel saving the **Setup**.

14) Finally, press the **MEAS** key to return to the measurement screen.

Note: The **Name** and **Comments** of the **Setup** can be edited at any time by simply repeating the **Save Setup** routine described above. Therefore, the **Save Setup** function can also be considered an **Edit Function**.

11.4 Using the Default Setup

The default setup feature was added to the **MMX-7** to use, as a last resort, if there are no setups stored in the gauge –factory or otherwise. The only time this might possibly occur is if the setup file in the **MMX-7** was somehow corrupted, and the user does not have access to a computer to re-load the factory setups back into the **MMX-7**. This gives the user the ability to load and modify a basic setup as follows:

Using the Default Setup

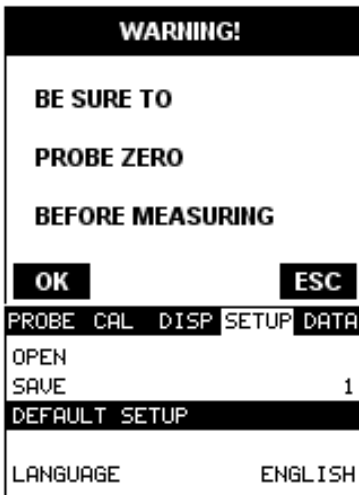

- 1) Press the **MENU** key once to activate the menu items tab. Press the **MENU** key multiple times to tab right and the **ESC** key multiple times to tab left until the **SETUP** menu is highlighted and displaying the submenu items.
- 2) Use the **UP** and **DOWN** arrow keys to scroll through the sub menu items until **DEFAULT SETUP** is highlighted.
- 3) Press the **ENTER** key to load the Default Setup and display the **Warning Message Box**.

Important Note: Remember to perform a probe zero function prior to measuring. The default setup clears the probe zero value.

- 4) Press the **OK** key to return to the measurement screen.

CHAPTER TWELVE USING THE UTILITY SOFTWARE

12.1 Computer System Requirements

MvxPvxView will run on many different operating systems: Windows 98 (1st or 2nd edition), Windows NT 4.0 with Service Pack 5, Windows ME, Windows XP, Windows 2000 Professional, Windows 2000 Server, or Windows 2000 Advanced Server operating systems running on Intel or AMD hardware.

A Pentium 166MHz or faster processor with at least 32 megabytes of physical RAM is required. You should have 40 megabytes of free disk space before attempting to install **MvxPvxView**.

MvxPvxView requires an available communications port in order to transfer data to and from the **MMX-7**. **MvxPvxView** supports COM1, COM2, COM3, and COM4.

USB to Serial Converter

Some newer laptop computers do not have standard serial ports. In this case it is possible to use a USB to Serial converter. If a serial to USB cable is needed, Contact Dakota Ultrasonics (pt# N-402-0510).

12.2 Installing MvxPvxView

MvxPvxView comes on a CD-ROM with an automatic installer program. Place the CD in your computer's CD tray and close the door. Open the CD-ROM by double clicking on the My Computer ICON, then double click on the CD. Finally, double click on the **SETUP** icon to begin the installation.

Refer to the help section in **MvxPvxView** software for the complete operating manual, setup, and operation.

APPENDIX A - VELOCITY TABLE

Material	sound velocity in/us		sound velocity m/s
Aluminum	0.2510		6375
Beryllium	0.5080		12903
Brass	0.1730		4394
Bronze	0.1390		3531
Cadmium	0.1090		2769
Columbium	0.1940		4928
Copper	0.1830		4648
Glass (plate)	0.2270		5766
Glycerine	0.0760		1930
Gold	0.1280		3251
Inconel	0.2290		5817
Iron	0.2320		5893
Cast Iron	0.1800	(approx)	4572
Lead	0.0850		2159
Magnesium	0.2300		5842
Mercury	0.0570		1448
Molybdenum	0.2460		6248
Monel	0.2110		5359
Nickel	0.2220		5639
Nylon	0.1060	(approx)	2692
Platinum	0.1560		3962
Plexiglas	0.1060		2692
Polystyrene	0.0920		2337
PVC	0.0940		2388
Quartz glass	0.2260		5740
Rubber vulcanized	0.0910		2311
Silver	0.1420		3607
Steel (1020)	0.2320		5893
Steel (4340)	0.2330		5918
Steel Stainless"	0.2230		5664
Teflon	0.0540		1372

MMX-7 Data Logging Ultrasonic Thickness Gauge

Tin	0.1310		3327
Titanium	0.2400		6096
Tungsten	0.2040		5182
Uranium	0.1330		3378
Water	0.0580		1473
Zinc	0.1660		4216
Zirconium	0.1830		4648

APPENDIX A - SETUP LIBRARY

Num	Name	Comment 1	Gn/AGC	Velocity
1	STEEL BASIC		45	0.2330 in/uSec
2	STEEL THRU PNT STD	¼ 5MHZ HD	15	0.2330 in/uSec
3	STEEL THRU PNT EXT	½ 3MHZ HD	14	0.2330 in/uSec
4	ALUMINUM W/GATE	¼" 7.5MHZ	45	0.2510 in/uSec
5	PLASTIC W/GATE THK	½ 1MHZ CPZT	45	0.0940 in/uSec
6	PLASTIC BASIC	¼ 2.25MHZ	45	0.0940 in/uSec

MATERIAL SAFETY DATA SHEET

N/A = not applicable or not available

(To comply with 29 CFR 1910.1200)

Effective Date: 2/1/04

SECTION 1 – PRODUCT IDENTIFICATION

Product Name: **SOUNDSAFE®**
Generic Name: Ultrasonic Couplant
Manufacturer: Sonotech, Inc.
774 Marine Dr., Bellingham, WA 98225
(360) 671-9121

NFPA Hazardous Materials
Identification System (est)
Health.....0
Flammability.....0
Reactivity.....0

SECTION 2 – HAZARDOUS INGREDIENTS

This material does not contain any ingredients having known health hazards in concentrations greater than 1%.

This material does not contain any known or suspected carcinogens.

SECTION 3 – PHYSICAL DATA (nominal)

Boiling Point: >220°F pH: 7.35 – 7.9
Freezing Point: <20°F Acoustic Imp.: 1.726x10⁶
Vapor Pressure: N/A Vapor Density: N/A
Evaporation Rate: N/A Specific Gravity: >1.02
Solubility in Water: complete
Appearance and Odor: water white, opaque gel;
bland odor

SECTION 4 – FIRE AND EXPLOSION HAZARD DATA

Flash Point: none
Upper Exposure Limit: none
Lower Exposure Limit: none
Special Fire Fighting Procedures: N/A
Extinguishing media: N/A
Unusual Fire and Explosion Hazards: none

SECTION 5 – REACTIVITY DATA

Stability: Stable
Conditions to Avoid: none
Incompatibility (Materials to Avoid): none known
Hazardous Polymerization: will not occur
Hazardous Decomposition or Byproducts: none known

SECTION 6 – HEALTH HAZARD AND FIRST AID DATA

Routes of Entry:¹
Skin: not likely Ingestion: not normally
Eyes: not normally Inhalation: no
Effects of Overexposure: *Acute:* May cause temporary
eye irritation
Chronic: none expected

First Aid Procedures:
Skin: Remove with water if desired.
Eyes: Flush with water for 15 minutes.
Ingestion: For large quantities, induce vomiting and
call a physician.
Inhalation: N/A

SECTION 7 – STORAGE AND HANDLING INFORMATION

Precautions to be taken in handling and storage: Store
between 20°F and 120°F. Spills are slippery and should
be cleaned up immediately.
Steps to be taken in case material is released or spilled:
Pick up excess for disposal. Clean with water.
Waste disposal method: Dispose of in accordance with
federal, state, and local regulations.

SECTION 8 – CONTROL MEASURES

Respiratory Protection: not required
Ventilation: not required
Protective Gloves: on individuals demonstrating
sensitivity to SOUNDSAFE®
Eye Protection: as required by working conditions
Other Protective Equipment: not required

¹SOUNDSAFE® contains only food grade and cosmetic grade ingredients.

SONOTECH, INC.

774 Marine Dr., Bellingham, WA 98225
Telephone: (360) 671-9121

Toll Free: 1-800-458-4254

Fax: (360) 671-9024

